

# Ensbury LT Boilers

Gas/Oil Fired Low Temperature Steel Boilers  
70kW to 580kW

## INSTALLATION, COMMISSIONING AND SERVICING INSTRUCTIONS

### IMPORTANT NOTE

THESE INSTRUCTIONS MUST BE READ  
AND UNDERSTOOD BEFORE INSTALLING,  
COMMISSIONING, OPERATING OR  
SERVICING EQUIPMENT



Heating *at work.*

# Customer After Sales Services

Telephone: **0845 450 2866** E-mail: **aftersales@hamworthy-heating.com** Fax: **01202 662522**

## **Technical Enquiries**

To supplement the detailed technical brochures, technical advice on the application and use of products in the Hamworthy Heating range is available from our technical team in Poole and our accredited agents.

## **Site Assembly**

Hamworthy offer a service of site assembly for many of our products in instances where plant room area is restricted. Using our trained staff we offer a higher quality of build and assurance of a boiler built and tested by the manufacturer.

## **Commissioning**

Commissioning of equipment by our own engineers, accredited agents or specialist sub – contractors will ensure the equipment is operating safely and efficiently.

## **Maintenance Agreements**

Regular routine servicing of equipment by Hamworthy service engineers inspects the safety and integrity of the plant, reducing the risk of failure and improving performance and efficiency. Maintenance agreements enable our customers to plan and budget more efficiently.

## **Breakdown service, repair, replacement**

Hamworthy provide a rapid response breakdown, repair or replacement service through head office at Poole and accredited agents throughout the UK.

## **Spare Parts**

A comprehensive spare parts service is operated from our factory in Poole, providing replacement parts for both current and discontinued products. Delivery of parts and components is normally from stock within seven days. However, a next day delivery service is available for breakdowns and emergencies.

# **Ensbury LT Boilers**

**Gas/Oil Fired Low Temperature Steel Boilers  
70kW to 580kW**

## **Installation, Commissioning and Servicing Instructions**

*NATURAL GAS I<sub>2H</sub>  
LPG PROPANE I<sub>3P</sub>  
CLASS D (35 sec fuel oil)  
Dual Fuel*

THE ENSBURY LT BOILER IS INTENDED FOR USE AS A COMMERCIAL APPLIANCE.

**THE GAS FIRED VARIANTS ARE FOR USE ON GROUP H NATURAL GAS (2<sup>ND</sup> FAMILY) I<sub>2H</sub> & LPG PROPANE (3RD FAMILY) I<sub>3P</sub>.**

**THE OIL FIRED VARIANTS ARE FOR USE ON CLASS D (35 sec FUEL OIL) or CLASS C2 - KEROSENE (28 sec OIL) OR BLENDED BIO- FUEL (RME or FAME). PLEASE ENSURE RELEVANT INFORMATION REQUIRED WITHIN THE DOCUMENT IS FOUND RELATING TO THE SPECIFIC FUEL TO BE FIRED, BEFORE OPERATING THE BOILER.**

THIS BOILER COMPLIES WITH ALL RELEVANT EUROPEAN DIRECTIVES.  
EC TYPE CERTIFICATE No. EC-0461

PUBLICATION NO. 500001192  
ISSUE 'B'  
October 2011

## CONTENTS

## PAGE

1.0	INTRODUCTION.....	4
2.0	SUPPLY AND DELIVERY.....	5
3.0	GENERAL REQUIREMENTS .....	7
4.0	SITE LOCATION AND PREPARATION .....	9
5.0	BOILER ASSEMBLY.....	15
6.0	PRE-COMMISSIONING .....	17
7.0	BOILER CHECKS PRIOR TO LIGHTING.....	18
8.0	CONTROLS AND OPERATION.....	21
9.0	FAULT FINDING .....	24
10.0	SERVICING.....	24
11.0	BURNER SELECTION.....	24
12.0	RECOMMENDED SPARES.....	30
APPENDIX A	PERFORMANCE DATA.....	32
APPENDIX B	ELECTRICAL CONNECTIONS AND CONTROLS.....	34
APPENDIX C	FLUE DATA .....	35
APPENDIX D	VENTILATION.....	36
APPENDIX E	WATER DATA.....	37

**FIGURES****PAGE**

Figure 1.1	3 pass boiler .....	4
Figure 2.1	General overview .....	5
Figure 2.2	Boiler package dimensions .....	6
Figure 3.1	Boiler connections .....	7
Figure 3.2	Boiler dimensions .....	7
Figure 3.3	Installation clearances .....	8
Figure 3.4	With / without vibration dampers .....	8
Figure 3.5	Clearance dimensions .....	8
Figure 4.6	Electrical connections .....	14
Figure 5.1	Cable route .....	15
Figure 5.2	Sensor pocket.....	15
Figure 5.3	Opening for burner cables .....	15
Figure 5.4	Sensor location .....	15
Figure 5.5	Wiring diagram.....	16
Figure 5.6	Turbulators.....	17
Figure 8.1	Control panel dimensions .....	22
Figure 8.2	Control identification .....	22
Figure 11.1	Burner matchings Nat Gas .....	24
Figure 11.2	Burner matchings LPG .....	25
Figure 11.3	Burner matchings oil.....	26
Figure 11.4	Burner matchings dual fuel .....	27
Figure 11.5	Oil nozzle selection.....	28
Figure 11.6	Target combustion figures .....	28
Figure 11.7	Combustion chamber and burner data .....	29
Figure 12.1	Spares identification .....	30
Figure 12.2	Control panel spares .....	30
Figure A1	Performance data Nat Gas.....	31
Figure A2	Performance data LPG.....	31
Figure A3	Performance data Class D Fuel Oil .....	32
Figure B1	Electrical connections .....	33
Figure D1	Mechanical Ventilation .....	35
Figure E 1	Water data .....	36
Figure E 2	Typical boiler installation .....	37
Figure E 3	Cold feed and vent sizes.....	38
Figure E 4	Variable Temperature Heating Circuit.....	38
Figure E 5	Constant and Variable Temperature Heating Circuits, with Domestic Hot Water .....	39

## 1.0 INTRODUCTION

**1.1** The Ensbury LT boiler range consists of 14 models, gas, oil or dual fuel fired, welded carbon steel boilers with outputs ranging from 70kW to 580kW. Refer to Technical Data in Appendix A for details on Natural gas, Propane and Oil firing. For applications firing blended Bio Fuel (RME or FAME), please refer to Hamworthy Heating Ltd for confirmation and guidance on the fuel specification.

Ensbury LT boilers are three pass, smoke tube boilers with combustion chamber and flue way using Low-Nox technology. The geometry of the combustion chamber and its relatively low volume, coupled with a patented flame escape system, allows for lower emission values and safe operation. The third pass is equipped with turbulators. Their turbulent action further increases the heat exchange and allows the system to work at low combustion gas temperatures, optimising efficiencies.

Ensbury LT boilers are suitable for minimum return temperatures down to 15°C and as a result, are suitable for direct connection to mixed temperature heating systems, delivering a minimum flow temperature of 60°C (50°C for oil firing) with no minimum flow rate requirements.

Ensbury LT boilers can be used individually, or in a multi-boiler configuration, and are suitable for use on either open-vented or sealed low temperature hot water heating systems. For hot water production they can be used in conjunction with calorifiers or indirect hot water cylinders.

Chesil pressurisation units are available from Hamworthy Heating Ltd for sealed systems.

**1.2** Ensbury LT boilers are supplied unassembled ready for on-site assembly.

The consignment consists of:

- a. Boiler body
- b. Casing panels
- c. Control panel
- d. Burner assembly

**1.3** Ensbury LT boilers have an operating efficiency of over 86% part load based on gross CV.

The heat exchanger is mounted within a steel frame, to which the casing and controls assemblies are fitted, leaving access for cleaning the appliance from the front. The heat exchanger assembly is provided with 100mm of glass fibre insulation

The flow / return and water drain connections are located at the rear of the boiler. Refer to Section 8 for details.

The Ensbury LT boiler can be fitted with either a high/low or modulating burner for operation on

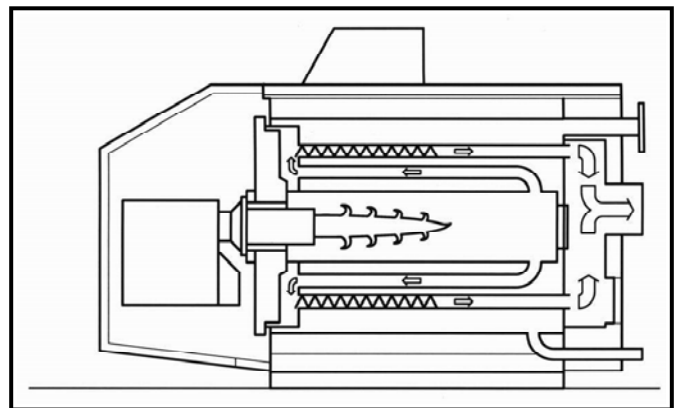
Natural Gas I<sub>2H</sub> (Second Family) or Propane I<sub>3P</sub> (Third Family) or a high/low or modulating burner for operation on Class D (35 second) fuel oil. In addition dual fuel option burners are available - see figures 11.1,2,3 & 4.

The boiler is supplied with a pre-wired control panel which contains:

- Control fuse 6.3 AT
- Limit thermostat 110°C manual reset
- Control thermostat 35°C to 90°C
- High fire control thermostat 35°C to 90°C
- Burner on off switch
- Limit thermostat test button
- Overheat indicator lamp
- Safety interlock indicator lamp
- Burner lock out lamp
- Water temperature thermometer
- High and low fire hours run meters
- 5 Volt free contacts for remote signalling

The boiler is housed in a powder coated sheet steel casing which is supplied flat-packed for on-site assembly. Refer to Section 10 for casing assembly procedure.

**1.3** All Ensbury LT boilers are factory hydraulically tested ensuring suitability for use on systems with maximum working pressures of up to 4 bar (55 psi).



**Figure 1.1 - 3 pass boiler**

## 2.0 SUPPLY AND DELIVERY

2.1 The boiler is normally supplied as a set of equipment comprising the following:

- a. Boiler body - with loose turbulators
- b. Casing panels
- c. Control panel
- d. Burner assembly - incl nozzles, where applicable

Remove all packing material and inspect the equipment to ensure that all parts are present and undamaged.

If in any doubt, DO NOT USE THE EQUIPMENT. , contact Hamworthy Heating Ltd.

All packaging materials are to be disposed of appropriately.

### Warranty

Full warranty assistance will be covered when the appliance is commissioned by Hamworthy Heating Ltd, see Terms & Conditions for full details.

**Hamworthy Heating Ltd will not accept any liability resulting from damage due to tampering, improper use, handling, installation errors, operation and maintenance. It is important to check for damage upon receipt of product, which if found must be notified to Hamworthy Heating Ltd immediately.**

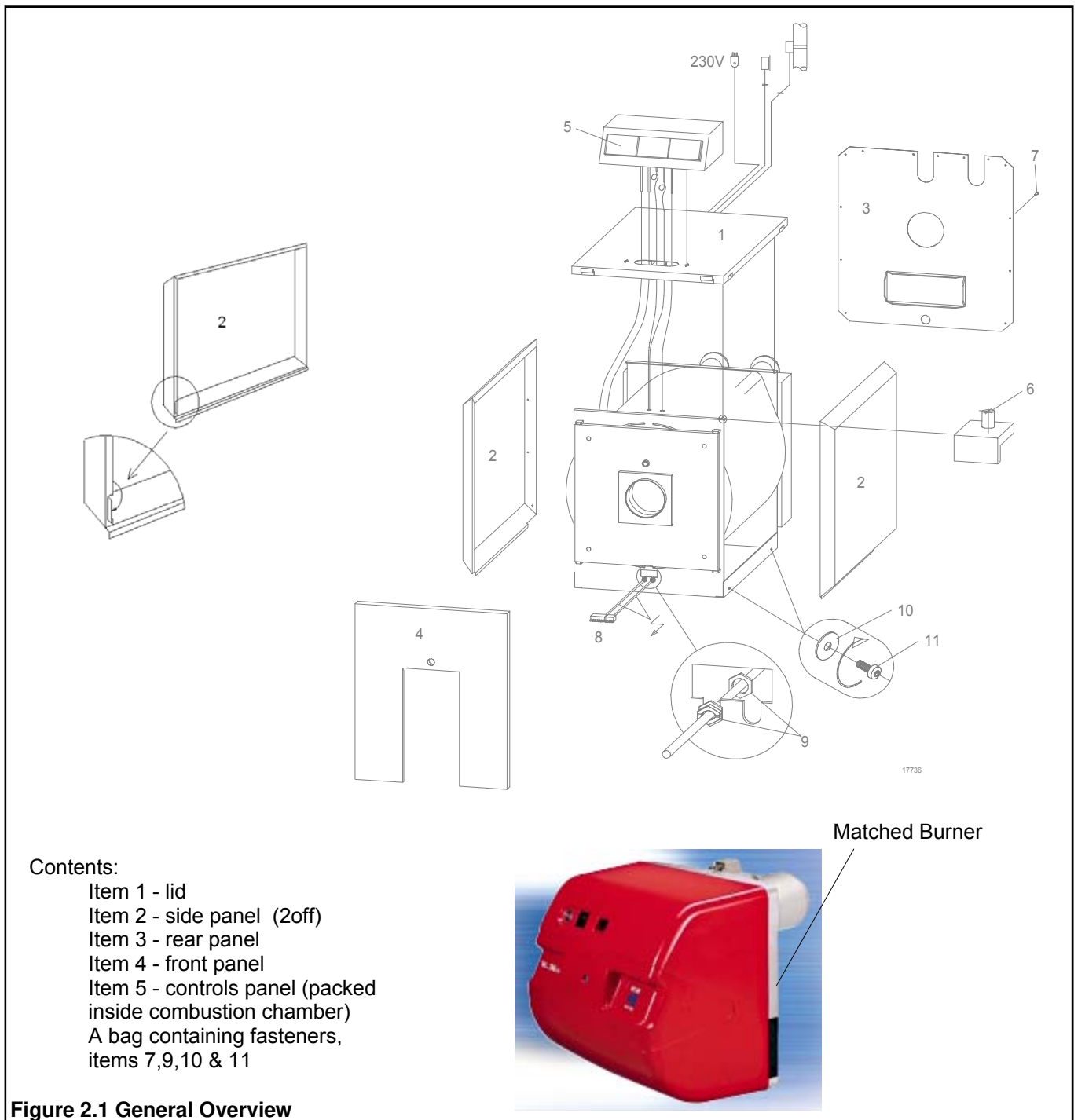


Figure 2.1 General Overview

## Delivery Verification

When taking delivery please ensure that you have received the correct number of boilers and ancillary parts to fulfil your order. The boiler and ancillary items are shipped on one pallet. The burner is shipped separately. The control panel and fasteners are located in the combustion chamber. The casing panels are secured to the top of the boiler body.

If any item is missing please contact our after sales service team. Please provide details of your order such as order number and contract number as well as a detailed description of the missing item.

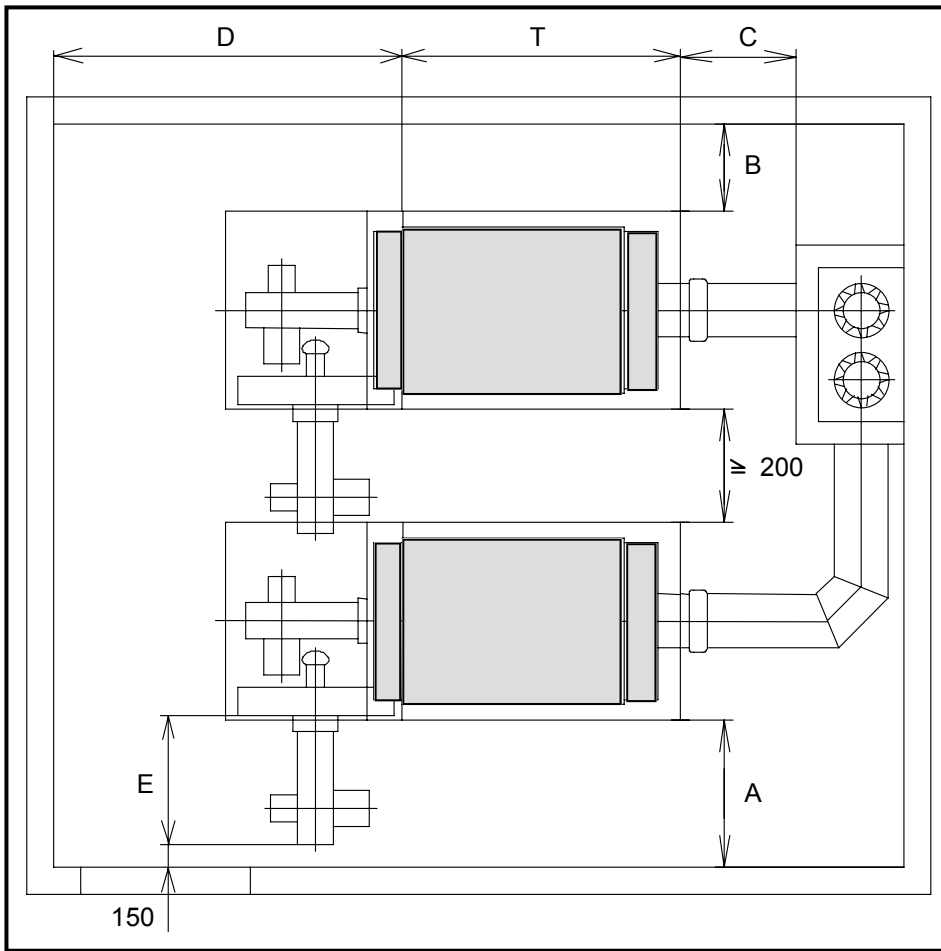
**Figure 2.2 - Boiler Packaged Dimensions**

<b>Model</b>	<b>H mm</b>	<b>W mm</b>	<b>L mm</b>	<b>Weight (kg) Excl. Burner</b>
<b>70/ 90</b>	1300	900	1200	284
<b>120/ 145</b>	1380	950	1300	394
<b>165/ 190</b>	1380	1050	1500	448
<b>225</b>	1460	1050	1500	522
<b>260/ 300</b>	1460	1200	1750	607
<b>335/ 370</b>	1550	1200	1750	739
<b>440/ 510/ 580</b>	1600	1200	2100	980

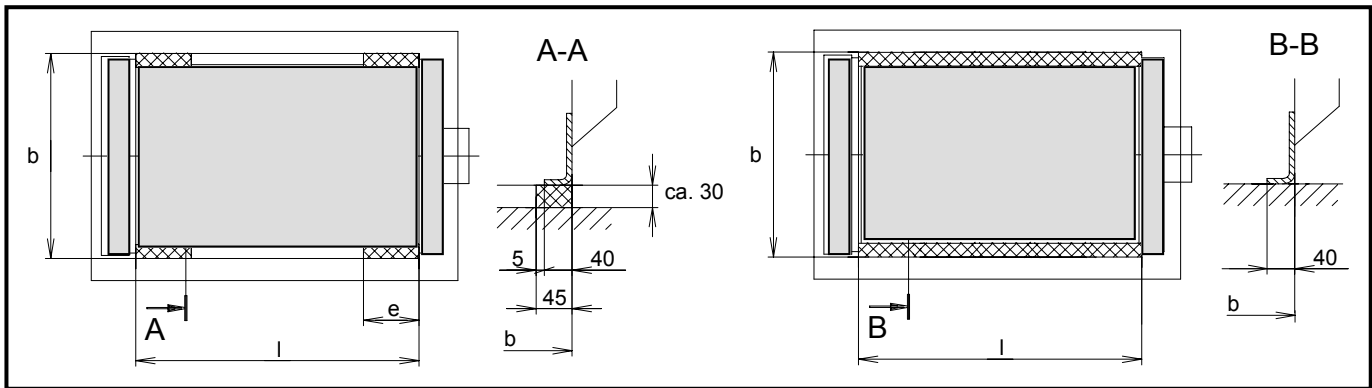




**Figure 3.3 - Clearances**



- A** It should be possible to open the furnace door, including burner, by 90° (door opening can be either to the left or to the right; right opening can be changed to left opening at the time of installing the boiler).  
At least 200 mm of free space should be provided to the right and to the left of the boiler to install boiler casing.
- B** After installing the casing, the boiler can be moved closer to the wall, but at least 60 mm away from it.
- C** The boiler cleaning hole behind the boiler must be easily accessible and should be 600 mm away from the wall.



**Figure 3.4 - with vibration dampers**

**without vibration dampers**

**Note:** -It is possible to mount the boiler on vibration dampers (available as option) to reduce noise transmission caused by vibrations. The dampers must be fitted prior to connecting the boiler to the system pipe work. To fit the dampers, some form of lifting device is required to locate the damper pads under the steel frame. Once the boiler is filled with water, it will sink 2-3mm into the damper pads.

Ensburly LT	Model	70	90	120	145	165	190	225	260	300	335	370	440	510	580
Front and rear	<b>D</b> mm	1220	1220	1310	1310	1310	1310	1310	1310	1310	1310	1310	1600	1600	1600
Boiler block length	<b>T</b> mm	1015	1015	1155	1155	1355	1355	1335	1615	1615	1615	1615	1870	1870	1870
Boiler feet length	<b>l</b> mm	844	844	986	986	1186	1186	1186	1445	1445	1445	1445	1701	1701	1701
Boiler feet width	<b>b</b> mm	640	640	740	740	740	740	790	790	790	870	870	938	938	938
Vibration damper length	<b>e</b> mm	130	130	130	130	130	130	130	274	274	274	274	274	274	274

**Figure 3.5 - Clearance dimensions**

## **4.0 SITE LOCATION AND PREPARATION**

### **4.1 Site Location.**

- The floor or plinth for the boiler(s), must be both flat and level to ensure correct alignment of fittings and connections.
- The floor or plinth must be sufficiently strong to support the weight of the boiler(s) (when full of water) and pipework.
- The floor or plinth must be fireproof in accordance with BS 6644.
- The plantroom must have sufficient space for installation of boilers, pipework, pumps controls, flues, ventilation, access and servicing and other items of plant.
- Sufficient space must be provided around the boiler to allow the removal of the burner assembly and opening of the burner door for servicing/replacement, and at the rear for installation of pipes, valves and flue.

### **4.2 Fuel Supply.**

- Gas supply pipes must be in accordance with BS 6891 or IGE/UP/2
- Gas supply connections to the boiler must not be smaller than the connection on the burner
- Gas installation must be soundness tested to BS 6891 or IGE/UP/1 & IGE/UP/1A.
- Gas installation must be purged to BS 6891 or IGE/UP/1 & IGE/UP/1A.
- Inlet gas pressure to boiler measured at the gas valve, nominal 20mbar (minimum 17.5mbar) dynamic - refer to Appendix A
- Where it is necessary to employ a gas pressure booster, the controls must include a low pressure cut-off switch at the booster inlet. It may be necessary to install a governor between the booster and gas train should the inlet pressure to the gas train exceed 50mbar - consult HHL for advice. The local gas region must be consulted before a gas pressure booster is fitted.
- Boiler house gas isolation valve must be clearly identified and installed close to the entrance / exit.
- The oil storage and supply system should be designed and installed in accordance with BS.5410 Part 2, as appropriate.
- Oil Supply Lines - The oil supply line(s) between storage tank and burner should be run in copper, steel or aluminium pipe. Galvanised pipes and fittings should not be used.
- The supply line should terminate adjacent to the burner with an isolating valve and metal bowl filter (with replaceable filter element). All burners are supplied with flexible oil pipes to make the final connection between the oil supply pipe and the burner.
- Liquid Bio Fuel quality **MUST** be in accordance with EN 1423 - consult Hamworthy Heating Ltd prior to installation and operation and seek assurances from the fuel supplier.

### 4.3 Flueing

- Flue termination, routing and construction must comply with the requirements of the Clean Air Act 1956, BS 6644, BS 5440 and IGE/UP/10 where applicable.
- Ensbury LT boilers are suitable for open flue (type B<sub>23</sub>) installation, drawing combustion air from the plant room - see section 5.2
- Due to the low flue gas temperature, (~180/200°C), upon start-up, condensation will occur in the flue, flue materials must be non-corrosive and utilise fully sealing joints.
- it is recommended that the flue system shall be adapted to its design diameter as soon as possible, after leaving the boiler.
- Flue systems must be self supporting, contain access for cleaning and contain a maintenance joint near the boiler outlet to allow for removal of the flue box during servicing.
- Ensbury LT boilers are suitable for installation in a balanced compartment in accordance with the requirements of BS 6644. Consult Hamworthy Heating Technical Department for help or assistance if in doubt.
- Existing chimneys should be thoroughly swept before use and any register plates, dampers, or restrictions removed.
- Chimneys should be lined with a non-porous acid-resistant material in accordance with BS.5854, e.g. a flexible flue liner or similar British Gas Approved material. The internal diameter of the liner must not be less than the recommended flue size and the number of joints should be kept to a minimum.
- It is recommended that a draught stabiliser is fitted to the flue system where the suction is likely to exceed 0.3mbar. The flue system should be designed to maintain atmospheric pressure or a slight suction at the boiler flue connection at all times (0.1 - 0.3mbar).
- Combustible materials in the vicinity of the boiler and flue shall not exceed 65 °C during boiler operation. The flue shall not be closer than 50mm to any combustible material, except where it passes through such material with a non-combustible sleeve when the air gap may not be less than 25mm.
- When designing the flue system, care must be taken to ensure that any condensate which may form within the system, can be safely drained to a suitable waste point and, that the flue material used is resistant to the corrosive effects of that condensate.

#### 4.4 Water Supply

- The Ensbury LT boiler is suitable for operating on open vented or sealed (pressurised) heating systems.
- Pressurised system to comply with BS 7074.
- Feed Water Quality - The condition of the feed water quality must be controlled:

Hardness	.....	- <100mg CaCO <sub>3</sub> /l.
pH	.....	8.3 - 9.5
Phosphates (PO <sub>4</sub> )	.....	- <30 mg/l
Chlorides (Cl)	.....	- <50 mg/l
Oxygen (O <sub>2</sub> )	.....	- <0.1 mg/l

- It is strongly recommended that the system pipework is flushed at least twice before adding water treatment and before installing the boiler.
- In hard water areas (>100mg CaCO<sub>3</sub>/litre) precautions such as water treatment are strongly recommended to prevent the build up of sludge and scale.
- Leaks in the system pipework must be repaired to prevent dilution of water treatment.
- Maximum working water pressure is 4bar.
- Minimum water pressure 0.5 bar
- Care must be taken to ensure that oxygen does not enter the system via the open feed tank, or system materials which allow the transmission of oxygen into the system.  
If this cannot be prevented, additional measures are necessary in the form of correctly used oxygen binding agents or chemicals.  
If it is not possible, consideration must be given for separation of the boiler from the system using for example plate heat exchangers.
- A coarse filter and dirt separator in the return to the boiler(s) MUST be fitted.

#### 4.4 General Requirements

- **Related Documents** - Gas Safety (Installation and Use) Regulations 1994 – (As amended). It is the law that all gas appliances are installed by competent persons, in accordance with the above regulations. Failure to do so, could lead to prosecution. It is in your own interest, and that of safety, to comply with the law. The installation of the boiler **MUST** be in accordance with the relevant requirements of the Gas Safety Regulations, Building Regulations, I.E.E. Regulations and the bylaws of the local water undertaking. The installation should also be in accordance with any relevant requirements of the local gas region and local authority and the relevant recommendations of the following documents :-
  - BS5410 - Code of practice for oil firing. Part 2: Installations of 44 kW and above capacity for space heating, hot water and steam supply purposes.
  - BS.6644 - Specification for installation of gas fired hot water boilers of rated inputs 60kW - 2MW.
  - BS 6700 Design, installation, testing and maintenance of services supplying water for domestic use.
  - BS 6891 Installation of low pressure gas pipe work of up to 35mm (R 1 ¼) in domestic premises.
  - BS 6880 Part 1, 2 & 3 Code of practice for low temperature hot water heating systems of output greater than 45kW.
  - BS 7074 Application, selection and installation of expansion vessels and ancillary equipment for sealed water systems. Part 2 Code of practice for low and medium temperature hot water systems.
  - BS 7671 Requirements for electrical installations. IEE Wiring Regulations. Seventeenth edition.
  - BSEN 806-2 Specification for installations inside buildings conveying water for human consumption. Design.
  - BSEN 12828 Heating systems in buildings, Design for water-based heating systems.
  - **I. Gas E. Publications**
    - IGE/UP/1 Soundness testing and purging of industrial and commercial gas installations.
    - IGE/UP/1A Soundness testing and direct purging of small low pressure industrial and commercial natural gas installations.
    - IGE/UP/2 Gas installation pipe work, boosters and compressors in industrial and commercial premises.
    - IGE/UP/10 Installation of gas appliances in industrial and commercial premises, Part 1 flued appliances.
  - **Health and Safety Executive**
    - Guidance note PM5 - Automatically controlled steam and hot water boilers.
  - **CIBSE Publications**
    - CIBSE Guide B Heating, ventilating, air conditioning and refrigeration.
    - CIBSE Guide H Building Control Systems
    - CIBSE Guide Energy Efficiency in Buildings
    - CIBSE Commissioning Code B: 2002
  - Dept Environment, Scottish Development Dept & Welsh Office
    - Third edition of the 1956 Clean Air Act Memorandum

## 4.6 Electrical Supply

**WARNING! THIS APPLIANCE MUST BE EARTHED IN ACCORDANCE WITH IEE REGULATIONS**

- **Boiler electrical supplies must not be switched by a time clock.**
- **Boilers are suitable for 230Volt, 50Hz supply. Burners are suitable for either 415Volt, 50Hz– 3 phase or 230Volt, 50Hz single phase supplies**
- **External fuses should be rated for 6.3 amps**
- **Wiring must be completed in heat resistant cable size 1.0mm<sup>2</sup> csa.**
- **Each boiler MUST have individual means of isolation.**
- **Electrical isolators must facilitate complete electrical isolation.**
- **Electrical isolators must have contact separation of minimum 3mm in all poles.**
- **Electrical isolators must be installed in readily accessible locations.**
- **Electrical supplies to boiler modules should only serve the boiler.**
- **Wiring of ancillary circuits must be connected to the control panel via the knock-outs in the rear of the panel, using suitable cable glands.**
- **Any pump controlled by the boiler must be installed using an adequate contactor.**
- **Where twin head pumps are installed a changeover control (not HHL supplied) external to the boiler is required.**
- **Where an external alarm is required, the control panel has 5 volt free contacts for remote signalling.**
- **Time clock control should be via the remote enable circuit (volt free).**
- **Any interlock circuit must be in series with the time control for each circuit. The interlock circuit must never be used to isolate the boiler electrical supply.**

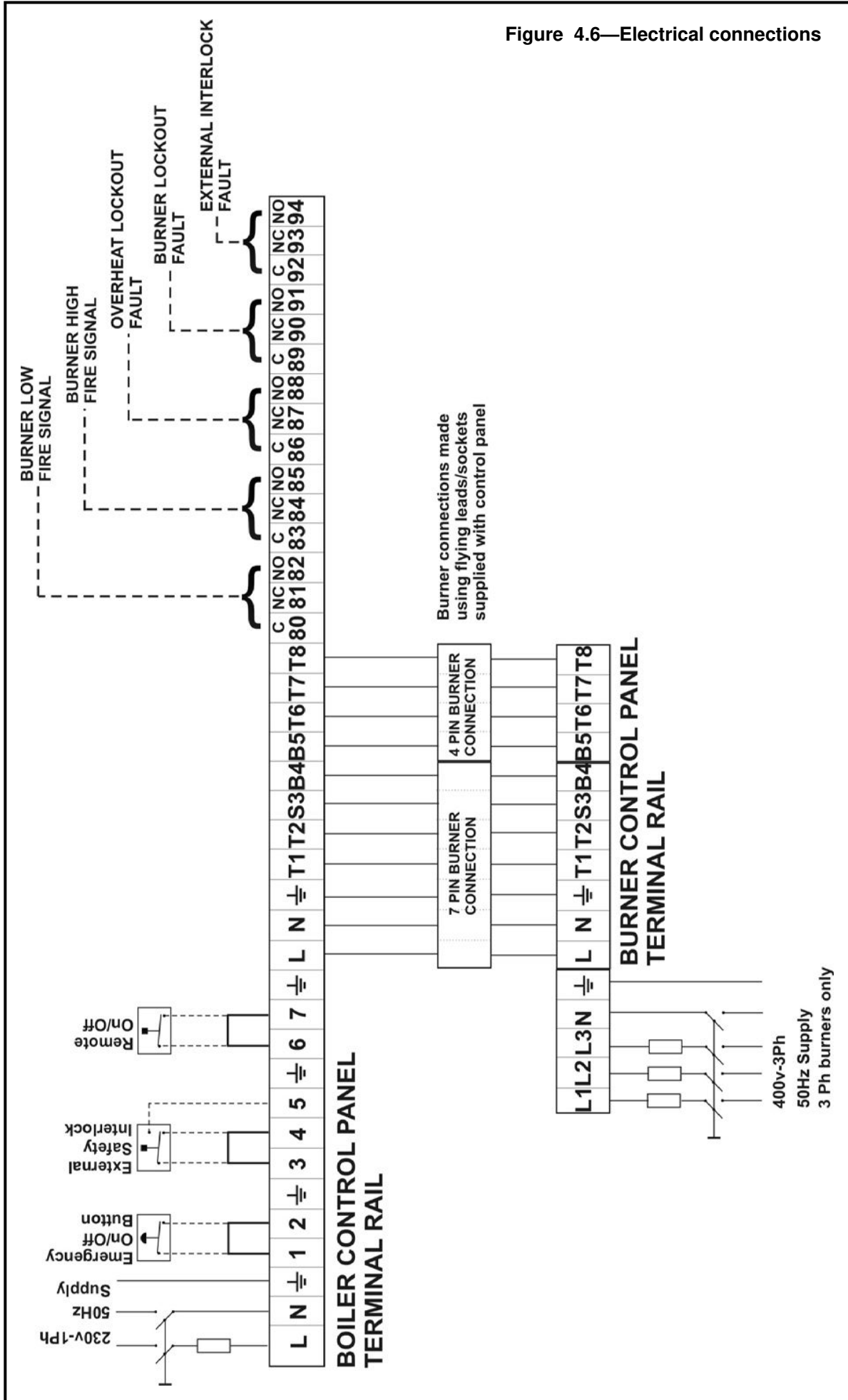
**ADDITIONAL INFORMATION REGARDING ELECTRICAL SUPPLIES IS GIVEN IN BS EN60335, Part 1.**

**NOTE: The appliance must be isolated from the electrical supply if electric arc welding is carried out on connecting pipework.**

**FOR TYPICAL SCHEMATIC DETAILS SEE FIGURE 4.6**

**FOR DETAILED WIRING INSTRUCTIONS SEE FIGURE 5.5**

Figure 4.6—Electrical connections





## 5.0 BOILER ASSEMBLY

**Important;** - fit the casing to the boiler body, **before** connecting the flue system.  
 Site equipment and accessories **MUST NOT** be secured to the casing panels.  
 Ancillary equipment wiring **MUST** be connected to the control panel using suitable cable glands at the rear of the panel.

### 5.1 Assembly

Referring to figure 2.1;

- a) Place the lid (1) onto the pins (6) on the boiler body. Carefully remove the knock-out using a suitable tool, to provide a route for the burner cables and capillaries to pass through the lid - see arrow figure 5.1..
- b) Place the boiler control panel (5) on the lid and carefully introduce the thermostat sensors through the lid opening and into the pockets. Fit a foam sleeve into the empty pockets when only 1 or 2 sensors are used. Secure in place using the spring clip - see figure 5.2 & 5.4 Secure the control panel to the lid using the screws provided (2) -see figure 5.1
- c) Route the burner cable(s) through the knock-out hole, running between the side panels and the boiler

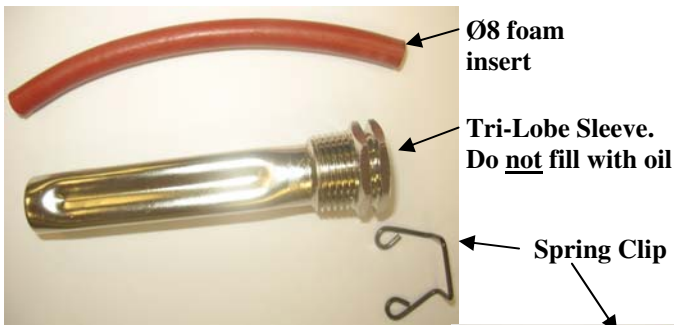


Figure 5.2 - Sensor pocket

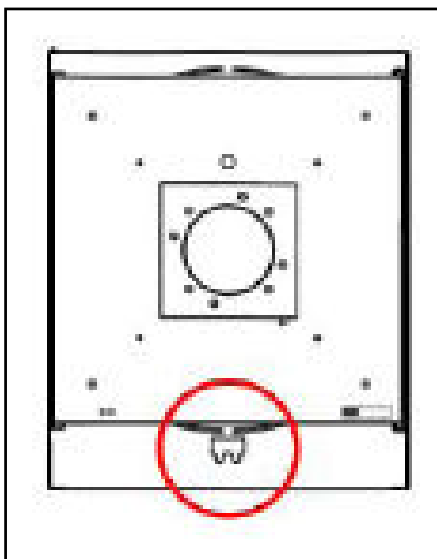


Figure 5.3—opening for burner cables

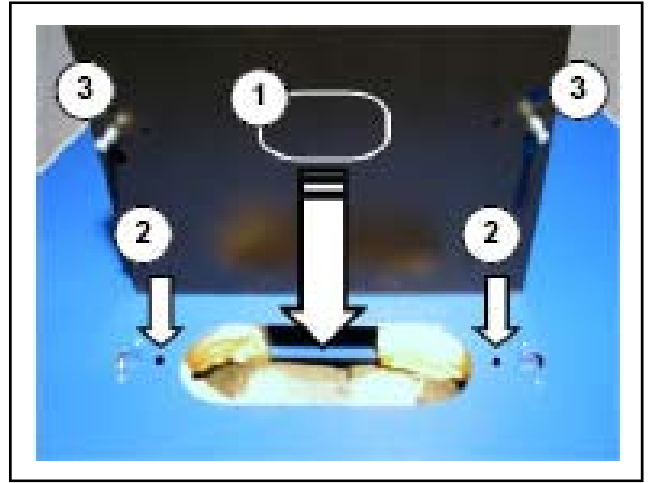


Figure 5.1 - Cable route

- d) Fasten cables (depending on burner) in the holes provided in the opening using the cable gland provided (9).
- e) Fold the tongues at the bottom of the side panels (2) by 90° towards the front. These serve as stops for the magnets of the front panel.
- f) Snap the side plates (2) to the lid and fasten them to boiler feet with washers (10) and screws (11).
- g) Fasten the rear panel (3) to the lid and side panels with the screws provided (7).
- h) Snap the front panel (4) to the front part of the lid and slide it downwards between the side plates until the magnets click to the stops.

### 5.2 Turbulators

The function of the turbulators is to control the flue gas temperature through the boiler.  
 All smoke tubes in the third pass must be fitted with turbulators. These smoke tubes are those located on the outer diameter, which are open at the rear, discharging into the flue gas collector.  
 Read and follow the instructions on the boiler door labels and the markings on the tube plate.

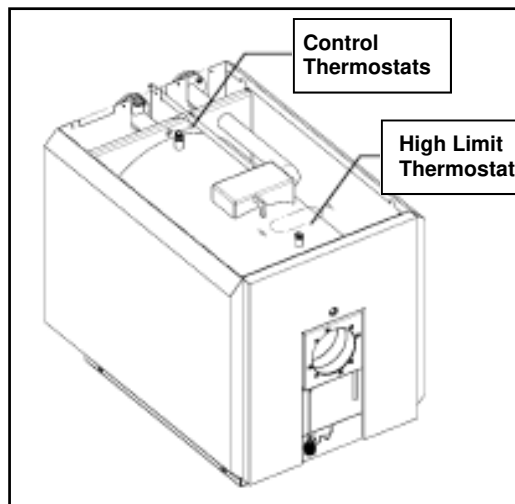
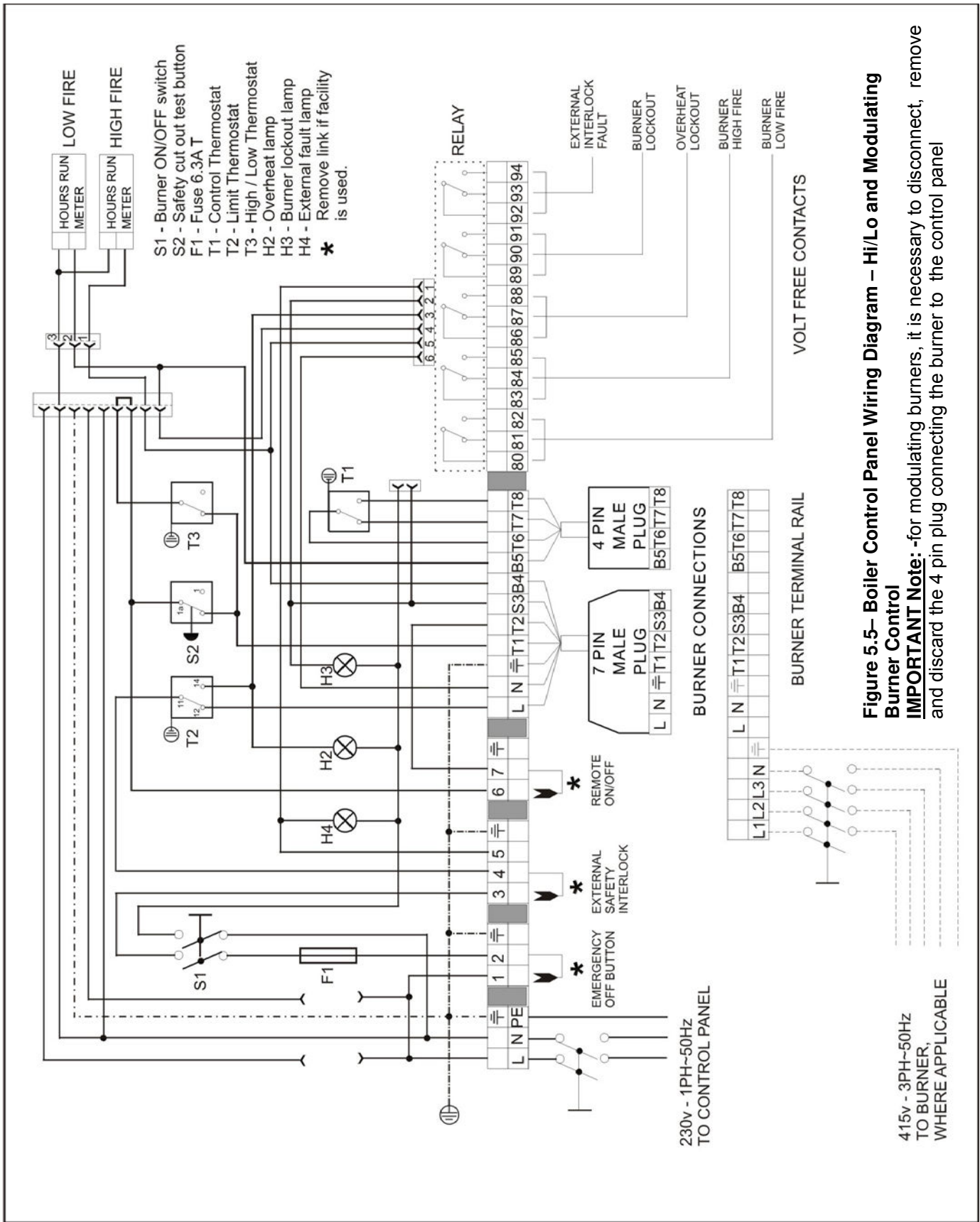


Figure 5.4 - Sensor location

**Important:** - the turbulators must be introduced and fed through the tube up to the stop created by the bent tail, otherwise, the door insulation may get damaged.



**Figure 5.5- Boiler Control Panel Wiring Diagram – Hi/Lo and Modulating Burner Control**  
**IMPORTANT Note:** -for modulating burners, it is necessary to disconnect, remove and discard the 4 pin plug connecting the burner to the control panel

Ensbury LT	Model	70	90	120	145	165	190	225	260	300	335	370	440	510	580	
Number of turbulators		9	9	11	11	11	11	15	15	15	19	19	25	25	25	
Outer diameter	MM	36														
Wire diameter	MM	6														
Pitch	MM	55														
Length	MM	400	600	600	800	600	800	800	800	400	600	600	800	400	600	1000

**Figure 5.6 - Turbulator**

### 5.3 Mounting the Burner

Before attempting to mount the burner, firstly ensure that the hole in the mounting plate is a clearance size for the burner blast tube diameter, and that the mounting stud pattern is correct for the burner flange. The hole in the mounting plate acts as a template for the boiler door insulation.

It is advisable to establish which direction the hinge will operate before fitting the burner. Adjust the hinge locknuts and handles to provide the necessary opening and check that the door seals correctly on the combustion chamber front before fitting the burner.

Fit the burner gasket over the studs and carefully mount the burner. Secure with the washers and nuts provided and tighten to form an effective seal on the gasket.

Open the boiler door and check that the burner blast tube is sitting correctly through the insulation, it is clean internally and the insulation is undamaged. There should be a small gap between the blast tube and the insulation on the door, this gap should be sealed with the insulation provided in the accessory pack, prior to firing the burner, in order to prevent hot gases from travelling backwards behind the insulation of the boiler door.

## 6.0 PRE-COMMISSIONING

The following pre-commissioning check must be carried out before the boiler is commissioned.

### 6.1 Gas Supply.

Ensure that gas installation pipework and meter has been soundness tested and purged to IGE/UP/1 or IGE/UP/1A as appropriate. Test and purge certificates should be available for viewing.

### 6.2 Ventilation

Ensure that ventilation and air supply to plantroom is correct.

### 6.3 Pipework, Valves and Pump

Ensure that;

- Pipework and valve arrangement is installed to Hamworthy Heating recommendations.
- Circulating system is full of water, vented and pressurised appropriately.
- Circulation pump is fitted, working and interlocked where required.
- Pipework connections to boiler are fitted correctly.
- All necessary isolation valves are open.
- Heat load is available.
- Safety valves are correctly rated and located.

### 6.4 Flue

Ensure that;

- Flue system is correctly designed and installed to suit boilers.
- Flue passages to chimney are clear.

### 6.5 Electrical

Ensure that;

- Electrical connections are correct and isolatable.
- External controls are operational.

## **7.0 BOILER CHECKS PRIOR TO LIGHTING**

**7.1 BEFORE** starting the boiler, check the following:

- Check that fuel supply is turned off.
- Check that electrical supply is isolated.
- Check that electrical installation conforms to the requirements of these Instructions, the IEE Wiring Regulations for electrical installations, and any other local Regulations which apply.
- Check boiler casings are undamaged Open boiler door to check that the flue turbulators are fitted.
- Check all thermostat bulbs are correctly inserted in the appropriate pockets.
- Check for water leaks and ensure that both boiler and heating system is full of water and properly vented.
- Check that all drain cocks are closed, and that all isolating valves in flow and return pipework are open.
- **For OIL**; check that tank/s have been filled and oil supply pipework between tank and burner has been primed.
- **For GAS**; Check that gas meter is operational and has been checked by the local gas supplier. If a gas booster has been installed, ensure that it has been commissioned in accordance with the manufacturer's instructions.

Check that gas meter and supply pipework is of sufficient size to meet the input rating of the burner/boiler. Refer to Figure 2.1.

- Check that burner output is correct for size of boiler in question, referring to Figure B.1, and the manufacturer's technical information supplied with the burner.
- **For GAS**; Check that gas meter is operational and has been checked by the local gas supplier.
- Check that gas meter and supply pipework is of sufficient size to meet the input rating of the burner/boiler. Refer to Figure 2.1.
- Check that burner output is correct for size of boiler in question, referring to Figure B.1, and the manufacturer's technical information supplied with the burner.

**NOTE: - ALL FUELS. Refer to the commissioning procedure in the burner manufacturers literature, before firing the boiler.**

**Always adjust the fuel supply upwards from a low position to ensure that a fuel rich mixture is not achieved.**

### **7.2 Commissioning Oil fired Boilers**

- Check flexible oil lines are tightly jointed and are not twisted or kinked to form an obstruction.
- Check correct nozzles are fitted to burner (See Fig. B.4, B.5 & B.6) and that they are tight.

NOTE:- Some burners are despatched with a test nozzle/s fitted. In these cases, the correct nozzle/s is despatched in a separate package with the boiler and **MUST** be fitted to the burner before attempting to fire the boiler.

- Check electrodes and ensure porcelain insulation is not cracked.
- Check electrodes are correctly positioned and gap is correctly set, as specified in the manufacturer's technical information supplied with the burner.
- Check blast tube is correctly located and securely fastened in place.
- Check burner seats correctly onto burner mounting plate and is securely fastened in place.
- Set burner for the required fuel and air throughputs, as specified in the manufacturer's technical information supplied with the burner.
- Fit a pressure gauge on burner oil pump to check pump pressure is correctly set.

- Check that temperature limiter manual reset button is pushed in, and that boiler control thermostat and control system are set to call for heat. Switch the boiler on and start the burner.
- The burner control will first operate the fan to pre-purge the boiler, then produce an ignition spark and finally open the oil solenoid valve and the flame should ignite.
- Purge air from oil pump through pressure gauge port.

**IF BURNER LOCKS OUT WAIT 45 SECONDS BEFORE PRESSING RESET BUTTON ON BURNER CONTROL BOX.**

- With burner firing, check the atomising pressure on gauge and adjust as necessary using the pressure regulator on burner oil pump. Refer to technical information supplied with burner.
- After allowing burner to reach stable firing conditions for approximately 15 minutes, carry out combustion gas check.  
Measure CO<sub>2</sub>, CO, smoke number, flue gas temperature and circulating water temperature rise across the boiler. The readings obtained should be as indicated in Figure B.7, target appliance readings.  
Readings should be taken at both High and Low settings. A switch is provided on the burner to hold the burner on low fire.
- Switch off boiler. Remove oil pressure gauge and replace sealing plug complete with gasket.
- Restart boiler and cycle it on and off several times to ensure reliable burner ignition and boiler operation. Check for oil, water and flue gas leakage. Tighten all access flue box and burner mounting bolts and nuts.
- Set boiler control thermostats to required setting, and check operation of heating control system.
- Fully familiarise the user with the boiler operating controls, the main component functions and the safety features.

**THESE INSTALLATION AND SERVICING INSTRUCTIONS SHOULD BE LEFT WITH THE USERS OF THE BOILER FOR THEIR FUTURE REFERENCE.**

**7.3 Commissioning Gas fired Boilers**

- Check that ignition electrode and rectification probe are correctly positioned. Refer to manufacturer's technical information supplied with the burner.
- Check that ignition electrode and rectification probe leads are connected.
- Check blast tube is correctly located, and securely fastened in place.
- Check burner seats correctly onto burner mounting plate and is securely fastened in place.
- With firing head separate from burner adjust air and gas settings, as specified in the manufacturer's technical information supplied with the burner.
- Determine minimum burner gas pressure which corresponds to required burner output (boiler input), as follows: - From the manufacturer's technical information (supplied with the burner) take burner pressure corresponding to required burner output.  
Add combustion resistance (in mbar), given in Appendix A for the boiler in question, to obtain gas pressure value to be measured at burner test point.
- Open main isolating valve in gas supply to boiler. Check for leaks throughout gas train and pipework to burner.
- Adjust gas supply governor to achieve at least 17.5 mbar (7.0 in.wg.) at inlet to boiler gas train. Ensure that maximum pressure of gas train governor is not exceeded. If a gas booster is to be fitted, commission in accordance with the manufacturer's instructions.
- Adjust start and main output gas rates as detailed in the manufacturer's technical information supplied with the gas burner.
- Check that temperature limiter manual reset button is pushed in, and that boiler control thermostat and control system are set to call for heat.
- Close main isolating valve in gas supply, switch the boiler on and start the burner. The burner control will first operate the fan to pre-purge the boiler, then produce an ignition spark and attempt to ignite the burner. The flame should fail to ignite and the burner should go to lockout.

- Open main isolating valve in gas supply. If gas train has separate pilot gas line, open pilot gas isolating valve and close main gas isolating valve. Restart boiler/burner. The burner control will pre-purge, produce an ignition spark and ignite pilot flame. The main flame should fail to light, and burner will continue running on ignition flame only. The pilot gas rate can be checked and adjusted as detailed in the manufacturer's technical information supplied with the gas burner.

**IF BURNER FAILS TO LIGHT, BOILER MUST BE PRE-PURGED BEFORE ATTEMPTING TO RESTART BURNER. IF BURNER REPEATEDLY FAILS TO LIGHT, A FULL INVESTIGATION TO FIND CAUSE SHOULD BE MADE.**

- Stop boiler/burner. Open main gas isolating valve and restart burner. The burner will pre-purge, ignite pilot flame and, after a short delay of several seconds, the main flame will light. Adjust the main gas rate as detailed in the manufacturer's technical information supplied with the gas burner.
- After allowing burner to reach stable firing conditions for approximately 15 minutes, carry out combustion gas check.  
Measure CO<sub>2</sub>, CO, flue gas temperature, and circulating water temperature rise across the boiler. The readings obtained for the appropriate gas should be as indicated in Figure B.7, target appliance readings. Readings should be taken at both High and Low settings. A switch is provided on the burner to hold the burner on low fire.
- After all other adjustments have been made, set burner air pressure switch as instructed in manufacturer's technical information supplied with burner.
- Check gas pressure at burner head corresponds with value determined from burner manufacturer's technical information - as detailed in (f) above.
- Check gas flow rate at meter. Ensure that all other appliances served by the meter are isolated whilst flow rate is checked.
- Cycle boiler on and off several times to ensure reliable burner ignition and boiler operation. Check for gas, water and flue gas leakage. Tighten all access, flue box and burner mounting bolts and nuts.
- Set boiler control thermostats to required setting, and check operation of heating control system.
- Fully familiarise the user with the boiler operating controls, the main component functions and the safety features.

**THESE INSTALLATION AND SERVICING INSTRUCTIONS SHOULD BE LEFT WITH THE USER OF THE BOILER FOR FUTURE REFERENCE.**

#### **7.4 External Controls**

The external controls used in typical boiler installations, for both vented and unvented systems, are shown in Figure 3.3. If different systems or controls are to be used and there are any doubts as to the suitability, contact Hamworthy Heating Technical Department for advice.

#### **7.5 Installation Noise**

In order to avoid the possibility of noise from the installation, care should be taken to follow the manufacturer's instructions. If acoustic insulation is added to the boiler, care must be taken not to impede combustion or ventilation air flow. If in doubt contact the manufacturer.

#### **7.6 User Instructions**

When the above is complete, the boiler owner or their representative should be made aware of the lighting and operating instructions. A practical demonstration should be given describing each functional step. This Installer's Guide and burner Operating Instructions and booster instructions (where fitted) should then be handed over and kept in a safe place for easy reference.

## **8.0 CONTROLS AND OPERATION**

### **8.1 Temperatures**

An adjustable control thermostat is supplied with each boiler and should be set to operate within the range 35-90°C for standard applications.

For high / low applications a second control thermostat is supplied that should be set around 5°C lower than the main control thermostat. This will enable the burner to switch to a lower firing rate as the water temperature approaches the set point.

A temperature limiter, (hand reset limit thermostat) is also fitted to the boiler and must be set at 100°C.

If a modulating burner is fitted, an additional temperature sensor must be fitted in the flow pipework and wired back to the modulating control on the burner, following the manufacturer's instructions. In this case, the high / low thermostat is superfluous and the appropriate 4 pin plug and flying lead can be disconnected from the boiler control panel. The thermostat sensor can be withdrawn from the pocket in the boiler flow pipe and the modulating temperature sensor can be inserted in the pocket. The 7 pin plug must remain connected in an unmodified condition in order to ensure that the temperature limiter remains in circuit. Set the boiler control thermostat to maximum. The boiler temperature control is carried out directly by the modulating controller on the burner to the temperature set point adjusted within the controller.

**NOTE:-** The minimum difference between control thermostat and temperature limiter **MUST NEVER** be less than 10°C.

Where the system is operating on a low temperature circuit care should be taken to ensure that the flow temperature set point does not fall below 60°C for gas or 50°C for oil.

### **8.2 Water Flow Controls**

Due to the design of the Ensbury LT boiler, it is not necessary to maintain a minimum flow through the boiler, as the water content and thermal mass of the boiler allow for the control of residual heat, without the operation of the high limit thermostat. This allows for more flexibility and tolerance in heating system design and eliminates the requirement for primary circuit pumps or boiler shunt pumps, hence reducing energy consumption.

However correctly sized circulating pumps and valves must be used in the system to provide the necessary performance.

### **8.3 Frost Protection**

Consideration should be given to fitting a frost thermostat set at approximately 4°C.

### **8.4 Unvented Systems**

See Figure E.3 for typical layout of a Unvented (Pressurised) Hot Water System.

For system design refer to **BS 7074-2**.

In order to correctly size a pressurisation unit for any heating system certain parameters are required :-

- 1) Static height of highest component in system (metres).
- 2) System volume - if it is not known a general rule of thumb of 10 litres/kW of installed boiler power can be used.
- 3) Maximum flow temperature (°C).
- 4) Maximum system hot working pressure, generally given in bar g.

From the above information Hamworthy Heating can size the pressurisation unit and also the expansion vessel required. Care must be taken in sizing expansion vessels to ensure maximum acceptance factors are not exceeded. Normally manufacturers of vessels impose a limit of 0.5. This value must not be exceeded at any time during the operation of the boiler: this includes the over pressure condition should a safety valve lift.

Consideration should also be given to sizing of the safety valve/s in the system.

See **BS EN ISO 4126-1**, for information.

See also **BS 6880-1**, for design considerations.

### **8.5 Multiple Boiler Control Schemes**

For multiple boiler installations, Hamworthy Heating can supply a unique boiler management control system called the 'Marshall HE'. This system comprises a wall mounted master control unit, which houses the main interface processor that will control up to 8 stages from a flow temperature sensor. Outside and room temperature sensors are optional. For further information, contact Hamworthy Heating for details.

### **8.6 Hours Run Meters**

All Ensbury LT boilers are fitted as standard with hours run meters, to enable the duty at both low and high fire to be monitored. If the boiler is set up for Modulation, both counters will register the same cyclic duty.

### **8.7 Modulating Burners**

The modulating burners from Riello are available as standard temperature control or optional 0-10v signal control.

**IMPORTANT;** the specification must be identified prior to delivery.

The temperature control version comes with a dedicated PT100 probe for insertion into the boiler flow pipe plus a bolt on control module, to influence the modulation rate of the burner as it approaches the desired set-point. To achieve this, the boiler control panel thermostats must be set to maximum.

The 0-10v signal version comes with a plug in module to convert a 0-10vdc control signal (input) to vary the position of the air damper servo motor and corresponding gas rate.

## 8.8 Operation

- 1 - Thermometer provides the temperature within the boiler body
- 2 - Burner On/Off switch allows the burner to be switched, without affecting any other devices or functionality.
- 3 - Safety cut out test button allows the testing of the Limit thermostat. By pressing the button, the boiler temperature will increase and shut down on the Limit thermostat, switching off the burner and

registering an overheat alarm lamp.

- 9 - Limit thermostat is activated if the boiler temperature exceeds the setting. Once activated, the manual reset cannot function until the boiler temperature has dropped by approximately 20°C. Once this has occurred, insert a thin screw driver into the hole and depress the button. The lamp will switch off immediately.

Always investigate the cause of overheat.

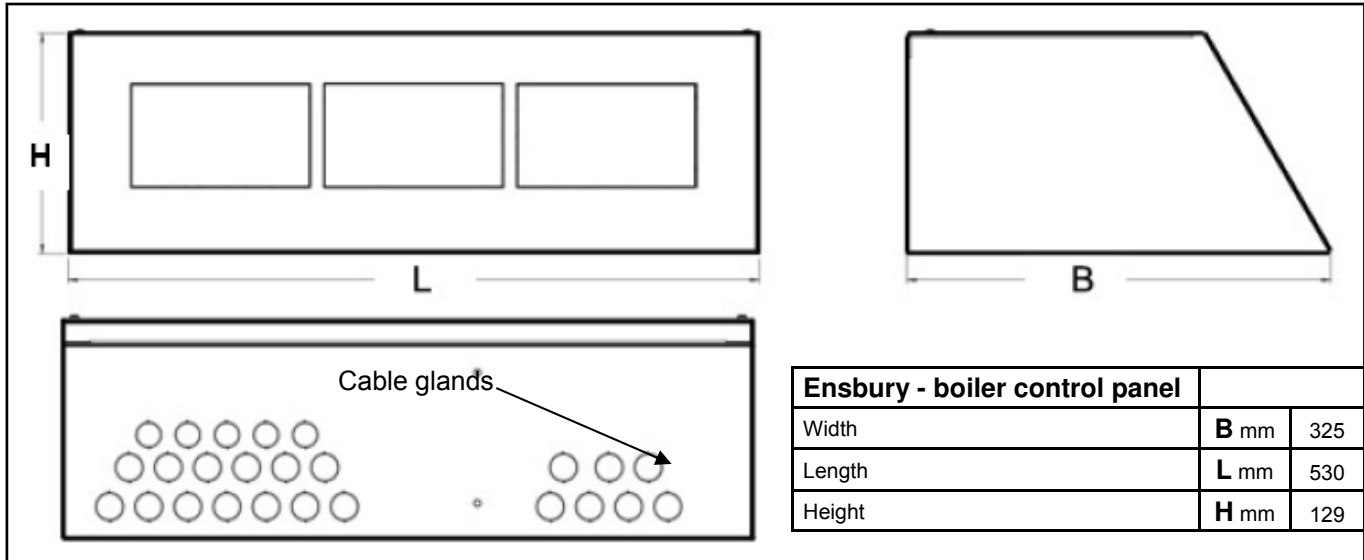


Figure 8.1 - Control panel dimensions

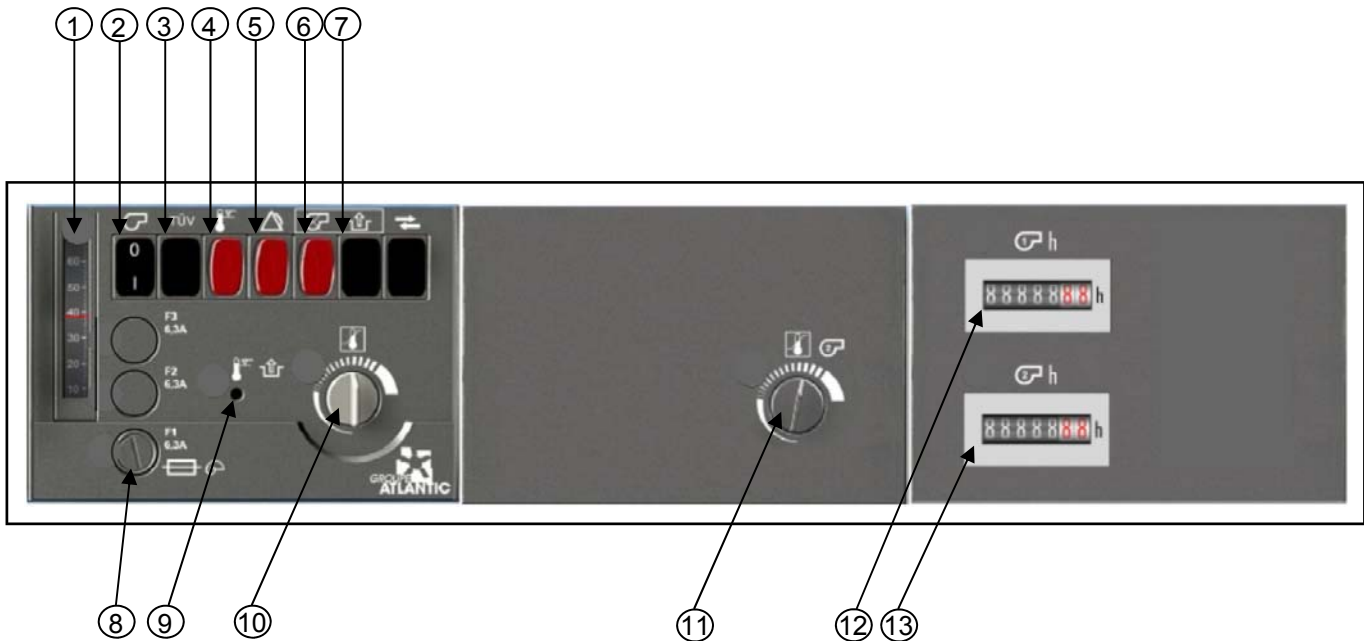


Figure 8.2 - Control identification

- 1 - Thermometer - water temperature
- 2 - Burner On/Off switch
- 3 - Safety cut out test button
- 4 - Alarm lamp - boiler overheat
- 5 - Alarm lamp - external safety interlock
- 6 - Alarm lamp - burner lockout

- 7 - Remote reset for burner - optional
- 8 - Fuse 6.3AT
- 9 - Limit thermostat - manual reset
- 10 - Stage 1 Thermostat (On/Off)
- 11 - Stage 2 Thermostat (High/Low)
- 12 - Hours Run meter - High fire
- 13 - Hours Run meter - Low fire



## **9.0 FAULT FINDING**

### **9.1 Fault Finding**

Fault finding on the burner control system is detailed in the burner manufacturers instructions. If the boiler still cannot be operated satisfactorily after following these instructions, consult Hamworthy Heating for assistance.

## **10.0 SERVICING**

A qualified engineer registered for working on non domestic gas or oil appliances should check and ensure that the flue, its support and terminal, the ventilation to the boiler house, safety valve, drain, water filter if fitted, pressure gauge, etc.; are in a serviceable and working condition and still comply with the relevant standards and codes of practice - see **Section 3.1**

The boiler should be serviced at regular intervals, not exceeding SIX months for oil fired boilers, or TWELVE months for gas fired boilers.

When carrying out boiler servicing always consider both your own safety and that of others. The use of protective equipment (e.g. eye protection, face mask, protective gloves, etc.) is recommended where necessary.

### **10.1 Initial Inspection**

**a.** Operate boiler and check for any signs of unsatisfactory operation, water leaks, gas leaks, oil leaks or unusual noise from burner oil pump or motor.

**b.** After allowing burner to reach stable firing conditions for approximately 15 minutes, carry out combustion gas check.

Measure CO<sub>2</sub>, CO, flue gas temperature, smoke number (for oil) and water temperature rise across the boiler. The readings obtained should be noted for reference upon completion of the servicing procedure.

**c.** Measure either gas pressure at burner head, or oil pressure at burner pump, as applicable, and check value is correct for size of boiler in question.

**d.** Check operation of both boiler and heating system controls, then set boiler control thermostat to OFF.

Allow the boiler/burner to cool.

### **10.2 Burner Service Procedure.**

#### **SWITCH OFF ELECTRICAL SUPPLY TO BOILER AT ISOLATOR AND SHUT OFF FUEL SUPPLY TO BOILER.**

Clean and service the burner in accordance with the burner manufacturers instructions.

**a.** Disconnect electrical and fuel connections to burner, as necessary.

**b.** Due to the design of the hinged door, it is preferable to leave the burner attached to the door for servicing, so as not to interfere with the blast

tube seal between the burner and the door. If for any reason the burner has to be removed, take great care so as not to damage the burner door insulation.

**c.** Loosen and remove the two nuts securing the burner door to the front of the boiler. Carefully hinge open the door with the burner attached to gain access to front of the combustion chamber and flue ways.

### **10.3 Boiler Service Procedure**

**a.** With the burner door hinged open access to the burner head is provided and the burner should be cleaned and serviced in accordance with the burner manufacturers instructions.

**b.** Carefully remove and store the turbulators. The boiler combustion chamber and heat exchanger flueways are now accessible for cleaning with suitable brushes and a vacuum cleaner.

**c.** An access panel is provided in the rear flue collector, to enable removal of any debris resultant from cleaning the heat exchanger tubes.

**d.** Carefully replace all turbulators as described in section 5.2

**e.** Replace all access/cover plates, ensuring that all gaskets and insulation panels are correctly fitted. Refit securing studs/nuts and tighten evenly.

**f.** Refit burner if removed—taking care to replace the blast tube seal. Reconnect fuel and electrical supplies.

**g.** Turn on fuel supply and check soundness of fuel supply pipework.

**h.** Check all flue joints for integrity.

**i.** Check ventilation ducts/grilles to boiler room and ensure they are clear.

**j.** Re-commission boiler as detailed in relevant parts of **Section 7.0: COMMISSIONING & TESTING**

## **11.0 BURNER SELECTION**

**Only matched burners must be used with the Ensbury LT boiler range. Refer to figures 11.1, 11.2, 11.3, & 11.4 .**

**Burner maintenance must be carried out by a competent person, in accordance with the manufacturer's instructions**

BOILER MODEL	BURNER DETAILS				BOILER DETAILS				COMBUSTION CHAMBER DETAILS			
	MAKE	MODEL	MODE	GAS TRAIN SIZE (in)	SUPPLY VOLTAGE 1Ph 230V - 3Ph 400V	NOMINAL HEAT INPUTS/OUTPUTS		MINIMUM HEAT INPUT BELOW WHICH A BURNER MUST NOT OPERATE (NETT)		DIAMETER (mm)	DIMENSIONS	
						HEAT OUTPUT (kW)	HIGH FIRE HEAT INPUT (NETT) (kW)	GAS RATE m <sup>3</sup> /hr	GAS RATE (kW)		LENGTH - REFER DIM. A FIG 11.7 (mm)	BLAST TUBE PENETRATION REFER TO DIM. B FIGURE 11.7 (mm)
70	RIELLO RIELLO	R40GS10D R40GS10/M	HI/LO MODULATING	0.75	✓	70	77	8.1	25	342	768	0
90	RIELLO RIELLO	R40GS20D R40GS10/M	HI/LO MODULATING	0.75	✓	90	99	10.5	50	342	768	5 0
120	RIELLO RIELLO	R40GS20D R40GS20/M	HI/LO MODULATING	0.75	✓	120	132	14.0	50	415	910	5
145	RIELLO RIELLO	R40GS20D R40GS20/M	HI/LO MODULATING	0.75	✓	145	159	16.9	50	415	910	5
165	RIELLO RIELLO	R40GS20D RS34/M MZ	HI/LO MODULATING	1.0 1.25	✓	165	181	19.2	50	415	1110	5 100
190	REILLO REILLO	RS34 MZ RS34/M MZ	HI/LO MODULATING	1.25	✓	190	209	22.1	60	415	1110	100
225	RIELLO RIELLO	RS34 MZ RS34/M MZ	HI/LO MODULATING	1.25	✓	225	247	26.2	60	463	1110	100
260	RIELLO REILLO	RS34 MZ RS34/M MZ	HI/LO MODULATING	1.5	✓	260	286	30.2	60	463	1366	100
300	RIELLO RIELLO	RS44 MZ RS44/M MZ	HI/LO MODULATING	1.5	✓	300	330	34.9	87	463	1366	100
335	RIELLO RIELLO	RS44 MZ RS44/M MZ	HI/LO MODULATING	1.5	✓	335	368	39.0	87	508	1366	100
370	RIELLO RIELLO	RS50M RS44/M MZ	HI/LO MODULATING	2.0	✓ x	370	407	43.0	87	508	1366	100
440	RIELLO RIELLO	RS50 RS50M	HI/LO MODULATING	1.5	✓	440	483	51.2	100	530	1618	100
510	RIELLO RIELLO	RS70 RS70M	HI/LO MODULATING	2.0	✓	510	560	59.3	100	530	1618	100
580	RIELLO RIELLO	RS70 RS70M	HI/LO MODULATING	2.0	✓	580	637	67.4	100	530	1618	135

**Note** To comply with the requirements of the Gas Appliance Directive, only the combinations listed below may be utilised for natural gas applications. Heat input values quoted above are based on Natural Gas (G20) with a net CV of 34.06 MJ/m<sup>3</sup> @ 1013mbar and 15°C.

Figure 11.1 – Matched Burner Boiler Combinations (Natural Gas)

BOILER MODEL	BURNER DETAILS				BOILER DETAILS				COMBUSTION CHAMBER DETAILS				
	MAKE	MODEL	MODE	GAS TRAIN SIZE (in)	SUPPLY VOLTAGE 1Ph 230V - 3Ph 400V	NOMINAL HEAT INPUTS/OUTPUTS		DIAMETER (mm)	LENGTH - REFER DIM. A FIG 11.7 (mm)	BLAST TUBE PENETRATION REFER TO DIM. B FIGURE 11.7 (mm)			
						HEAT OUTPUT (kW)	HIGH FIRE HEAT INPUT (NETT) (kW)				GAS RATE m <sup>3</sup> /hr	MINIMUM HEAT INPUT BELOW WHICH A BURNER MUST NOT OPERATE (NETT) (kW)	GAS RATE m <sup>3</sup> /hr
70	RIELLO RIELLO	R40GS10D R40GS10M	HI/LO MODULATING	0.75	✓	70	79	3.2	25	1.0	342	768	0
90	RIELLO RIELLO	R40GS10D R40GS10M	HI/LO MODULATING	0.75	✓	90	101	4.1	50	2.0	342	768	0 0
120	RIELLO RIELLO	R40GS20D R40GS20M	HI/LO MODULATING	0.75	✓	120	135	5.5	50	2.0	415	910	5
145	RIELLO RIELLO	R40GS20D R40GS20M	HI/LO MODULATING	0.75	✓	145	163	6.7	50	2.0	415	910	5
165	RIELLO RIELLO	R40GS20D RS34/M MZ	HI/LO MODULATING	1.0 1.25	✓	165	185	7.6	50	2.0	415	1110	5 100
190	RIELLO RIELLO	RS34MZ RS34/M MZ	HI/LO MODULATING	1.25	✓	190	213	8.7	60	2.5	415	1110	100
225	RIELLO RIELLO	RS34MZ RS34/M MZ	HI/LO MODULATING	1.25	✓	225	252	10.3	60	2.5	463	1110	100
260	RIELLO RIELLO	RS34MZ RS34/M MZ	HI/LO MODULATING	1.25	✓	260	292	11.9	60	2.5	463	1366	100
300	RIELLO RIELLO	RS34MZ RS34/M MZ	HI/LO MODULATING	1.25	✓	300	337	13.8	87	3.7	463	1366	100
335	RIELLO RIELLO	RS44MZ RS44/M MZ	HI/LO MODULATING	1.25	✓	335	376	15.4	87	3.7	508	1366	100
370	RIELLO RIELLO	RS44MZ RS44/M MZ	HI/LO MODULATING	1.25	✓	370	416	17.0	87	3.7	508	1366	100
440	RIELLO RIELLO	RS44MZ RS44/M MZ	HI/LO MODULATING	1.25	✓	440	494	20.2	100	4.0	530	1618	100
510	RIELLO RIELLO	RS70 RS70/M	HI/LO MODULATING	1.25	✓	510	573	23.4	100	4.0	530	1618	100
580	RIELLO RIELLO	RS70 RS70/M	HI/LO MODULATING	1.5	✓	580	651	26.6	100	4.0	530	1618	135

Figure 11.2 – Matched Burner Boiler Combinations (LPG Propane)

**NOTE!** To comply with the requirements of the Gas Appliance Directive, only the combinations listed below may be utilised for LPG applications. Heat input values quoted above are based on Propane (G31) with a net CV of 88 MJ/m<sup>3</sup> @ 1013mbar and 15°C.

BOILER MODEL	BURNER DETAILS				BOILER DETAILS				COMBUSTION CHAMBER DETAILS			
	MAKE	MODEL	MODE	SUPPLY VOLTAGE 1Ph 230V - 3Ph 400V	NOMINAL HEAT INPUTS/OUTPUTS			DIMENSIONS		DIAMETER (mm)	LENGTH – REFER DIM. A FIG 11.7 (mm)	BLAST TUBE PENETRATION REFER TO DIM. B FIGURE 11.7 (mm)
					HEAT OUTPUT (kW)	HIGH FIRE HEAT INPUT (NETT) (kW)	OIL FLOW RATE l/h	MINIMUM HEAT INPUT BELOW WHICH A BURNER MUST NOT OPERATE (NETT) (kW)	OIL FLOW RATE l/h			
70	RIELLO	R40G10I	HI/LO	✓	70	80	8.1	38	3.7	342	768	0
90	RIELLO	R40G20D	HI/LO	✓	90	102	10.4	61	6.1	342	768	5
120	RIELLO	R40G20D	HI/LO	✓	120	136	13.8	61	6.1	415	910	5
145	RIELLO	R40G20D	HI/LO	✓	145	165	16.7	61	6.1	415	910	5
165	RIELLO	RL34 MZ RL28M	HI/LO MODULATING	✓	165	188	19.0	83	8.4	415	1110	100
190	REILLO	RL34 MZ RL28M	HI/LO MODULATING	✓	190	216	21.9	83	8.4	415	1110	100
225	RIELLO	RL34 MZ RL28M	HI/LO MODULATING	✓	225	256	26.0	83	8.4	463	1110	100
260	RIELLO	RL34 MZ RL28M	HI/LO MODULATING	✓	260	296	30.0	83	8.4	463	1366	100
300	RIELLO	RL44 MZ RL28M	HI/LO MODULATING	✓ x	300	341	34.6	133	13.5	463	1366	100
335	RIELLO	RL44 MZ R44MZ RL38M	HI/LO HI/LO MODULATING	✓ x x	335	381	38.6	133	13.5	508	1366	100
370	RIELLO	RL50 RL38M	HI/LO MODULATING	✓	370	421	42.7	133	13.5	508	1366	100
440	RIELLO	RL50 RL50M	HI/LO MODULATING	✓	440	500	50.8	127	12.9	530	1618	100
510	RIELLO	RL50 RL50M	HI/LO MODULATING	✓	510	580	58.8	127	12.9	530	1618	100
580	RIELLO	RL70 RL70M	HI/LO MODULATING	✓	580	659	66.9	219	22.2	530	1618	135

**NOTE!** Heat input values quoted above are based on class D Fuel Oil with a net CV of 35.47 MJ/litre @ 15°C Operation on Class C2 Kerosene is achieved by setting the burner nozzle pressure to the appropriate level. In the case of blended liquid Bio Fuel (RME or FAME), please consult with Hamworthy Heating Ltd, to confirm the specification of the fuel, and the necessary settings to achieve optimum performance The bio fuel **MUST** be manufactured in accordance with EN14213 .

Figure 11.3 – Matched Burner Boiler Combinations (Class D Oil)

BOILER MODEL	BURNER DETAILS				BOILER DETAILS				COMBUSTION CHAMBER DETAILS				
	MAKE	MODEL	MODE	GAS TRAIN SIZE (in)	SUPPLY VOLTAGE 1Ph 230V - 3Ph 400V	HEAT OUTPUT		NOMINAL HEAT INPUTS/OUTPUTS		DIAMETER	DIMENSIONS		
						(kW)		HIGH FIRE HEAT INPUT (NETT)	MINIMUM HEAT INPUT BELOW WHICH A BURNER MUST NOT OPERATE (NETT)		LENGTH - REFER DIM. A FIG 11.7	BLAST TUBE PENETRATION REFER TO DIM. B FIGURE 11.7	
						(kW)		(kW)	(kW)	(mm)	(mm)	(mm)	
70													
90													
120													
145													
165	RIELLO	RLS28	HI/LO	1.25	✓	165	181	19.2	50	2.0	415	1110	75
190	REILLO	RLS28	HI/LO	1.25	✓	190	209	22.1	60	2.5	415	1110	75
225	RIELLO	RLS28	HI/LO	1.25	✓	225	247	26.2	60	2.5	463	1110	75
260	RIELLO	RLS28	HI/L	1.5	✓	260	286	30.2	60	2.5	463	1366	75
300	RIELLO	RLS38	HI/LO	2.0	✓	300	330	34.9	87	3.7	463	1366	85
335	RIELLO	RLS38	HI/LO	2.0	✓	335	368	39.0	87	3.7	508	1366	85
370	RIELLO	RLS50	HI/LO	2.0	✓	370	407	43.0	87	3.7	508	1366	100
440	RIELLO	RLS70	HI/LO	1.5	✓	440	483	51.2	100	4.0	530	1618	100
510	RIELLO	RLS70	HI/LO	2.0	✓	510	560	59.3	100	4.0	530	1618	135
580	RIELLO	RLS70	HI/LO	2.5	✓	580	637	67.4	100	4.0	530	1618	135

**Note** To comply with the requirements of the Gas Appliance Directive, only the combinations listed below may be utilised for natural gas applications. Heat input values quoted above are based on Natural Gas (G20) with a net CV of 34.06 MJ/m<sup>3</sup> @ 1013mbar and 15°C.

Figure 11.4 – Matched Burner Boiler Combinations (Dual Fuel Nat Gas (modulating) /Oil (Hi/Lo))

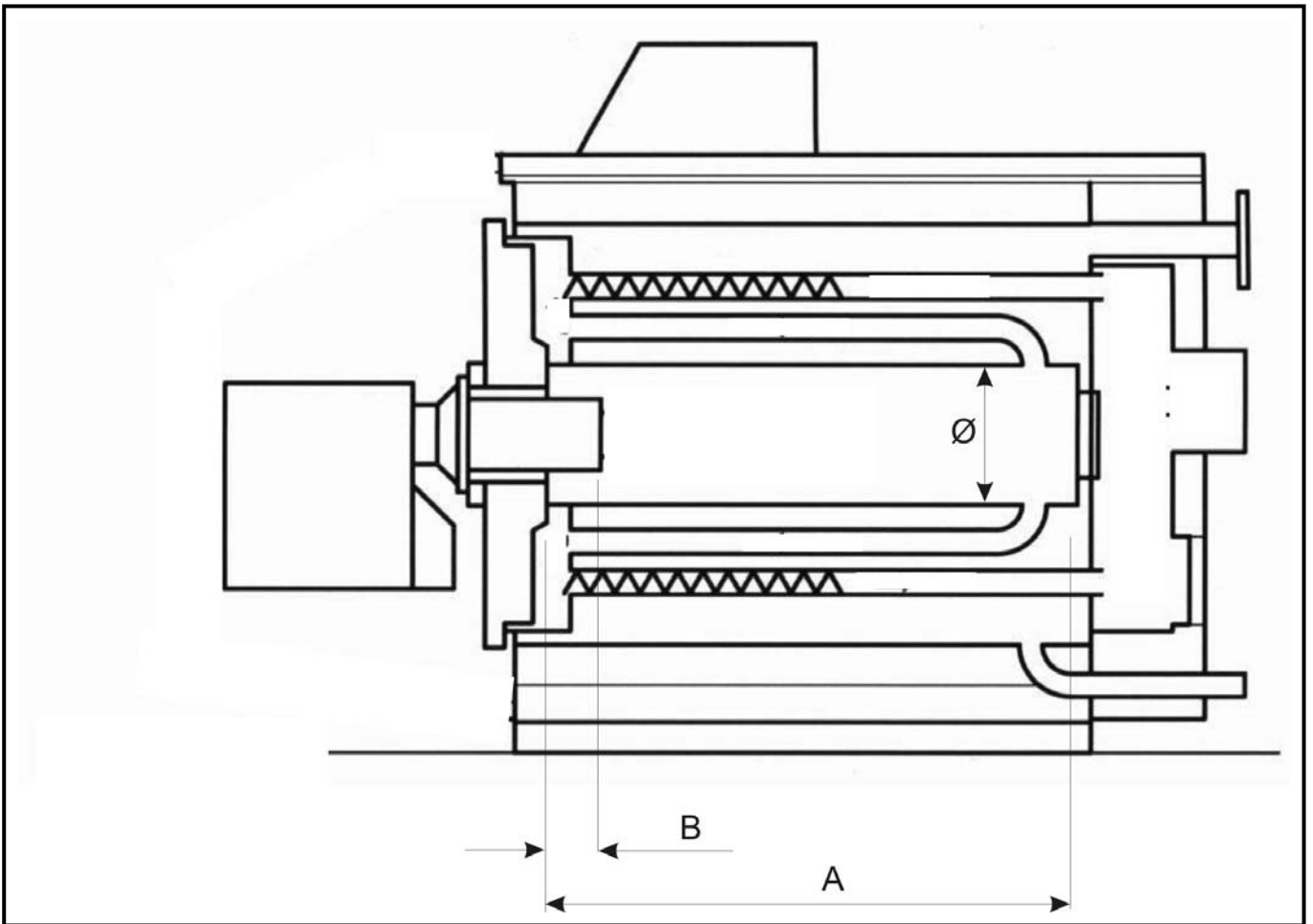
MAKE (type)	MODEL	MODE	QUANTITY	PART No.	DESCRIPTION	
RIELLO (Danfoss/ Berzano)	70	HI/LO	1	532904014	1.5 x 60°	
	90	HI/LO	1	532904004	2.0 x 60°	
	120	HI/LO	1	532904005	2.5 x 60°	
	145	HI/LO	1	532904006	3.0 x 60°	
	165	MODULATING	HI/LO	1	532904004	2.0 x 60° - (Low)
				1	532904056	1.75 x 60° - (High)
				1	532904077	20kg/hr
	190	MODULATING	HI/LO	1	532904011	2.25 x 60° - (Low)
				1	532904004	2.0 x 60° - (High)
				1	532904077	20kg/hr
	225	MODULATING	HI/LO	1	532904012	2.75 x 60° - (Low)
				1	532904011	2.25 x 60° - (High)
				1	532904078	30kg/hr
	260	MODULATING	HI/LO	1	532904006	3.0 x 60° - (Low)
				1	532904012	2.75 x 60° - (High)
				1	532904078	30kg/hr
	300	MODULATING	HI/LO	1	532904007	3.5 x 60° - (Low)
				1	532904006	3.0 x 60° - (High)
			1	532904078	30kg/hr	
335	MODULATING	HI/LO	1	532904008	4.0 x 60° - (Low)	
			1	532904007	3.5 x 60° - (High)	
			1	532904118	40kg/hr	
370	MODULATING	HI/LO	1	532904009	4.5 x 60° - (Low)	
			1	532904008	4.0 x 60° - (High)	
			1	532904118	40kg/hr	
440	MODULATING	HI/LO	1	532904016	5.5 x 60° - (Low)	
			1	532904009	4.5 x 60° - (High)	
			1	532904103	50kg/hr	
510	MODULATING	HI/LO	1	532904017	6.0 x 60° - (Low)	
			1	532904015	5.0 x 60° - (High)	
			1	532904103	50kg/hr	
580	MODULATING	HI/LO	1	532904020	7.0 x 60° - (Low)	
			1	532904017	6.0 x 60° - (High)	
			1	532904104	60kg/hr	

Figure 11.5 – Oil Nozzle Selection

Fuel Type	BOILER MODEL	70	90	120	145	165	190	225	260	300	335	370	440	510	580
Natural Gas G20	CO <sub>2</sub> (DRY)	9 - 10%													
	CO	Less than 100 ppm (air free)													
	Flue Gas Temp Rise °C	180 - 190 °C													
	Temp Rise Across Boiler	Less than 20 °C													
LPG Propane G31	CO <sub>2</sub> (DRY)	11 - 12%													
	CO	Less than 100 ppm (air free)													
	Flue Gas Temp Rise °C	180 - 190 °C													
	Temp Rise Across Boiler	Less than 20 °C													
Class D Fuel Oil	CO <sub>2</sub> (DRY)	11 - 12%													
	CO	Less than 100 ppm (air free)													
	Flue Gas Temp Rise °C	180 - 190 °C													
	Temp Rise Across Boiler	Less than 20 °C													
	Smoke No	Less than 1													

Figure 11.6 – Target Appliance Readings.

**Note !** The above target values provide an approximate guide with which to attain nominal operation of the appliance so as to satisfy the requirements of the Boiler Efficiency Directive



**Figure 11.7 – Combustion Chamber and Burner Data - refer to figures 11.1, 11.2, 11.3 & 11.4**

## **12.0 REPLACEMENT OF PARTS**

There are a number of components listed below which can be replaced simply and quickly by following the given procedure. In each case the operation of each replaced component must be checked by carrying out the appropriate part of the commissioning procedure. See **Section 11.0: COMMISSIONING & TESTING**.

**NOTE: Isolate all electrical supplies to the boiler and turn off the gas supply before removing controls cover and commencing any servicing or component exchange procedure.**

**Note :** -For replacement of burner components refer to the burner manufacturers instructions.

### **12.1 Control and High/Low Thermostat(s)**

Record the existing temperature setting of the thermostat for reference before removal.

**NOTE:** before attempting to hinge the fascia down, the thermostat knobs must be pulled off and the temperature limiter (high limit) cover knob unscrewed and removed.

Remove the upper front casing panel. Turn the two latches a quarter turn using a screwdriver or coin and lift off. The fascia can then be hinged downwards by unlatching the catch on the top right

hand using a screwdriver.

Withdraw the appropriate thermostat bulb from the thermostat pocket and disconnect the electrical connections noting the terminal identifications.

Remove the two screws securing the thermostat to its mounting bracket and withdraw the thermostat body whilst feeding the capillary through the hole in the control panel mounting plate.

Fit the new thermostat and ensure the capillary is correctly located within the thermostat pocket. Close the fascia and run the boiler to check for correct operation. Set the thermostat to the previously noted setting.

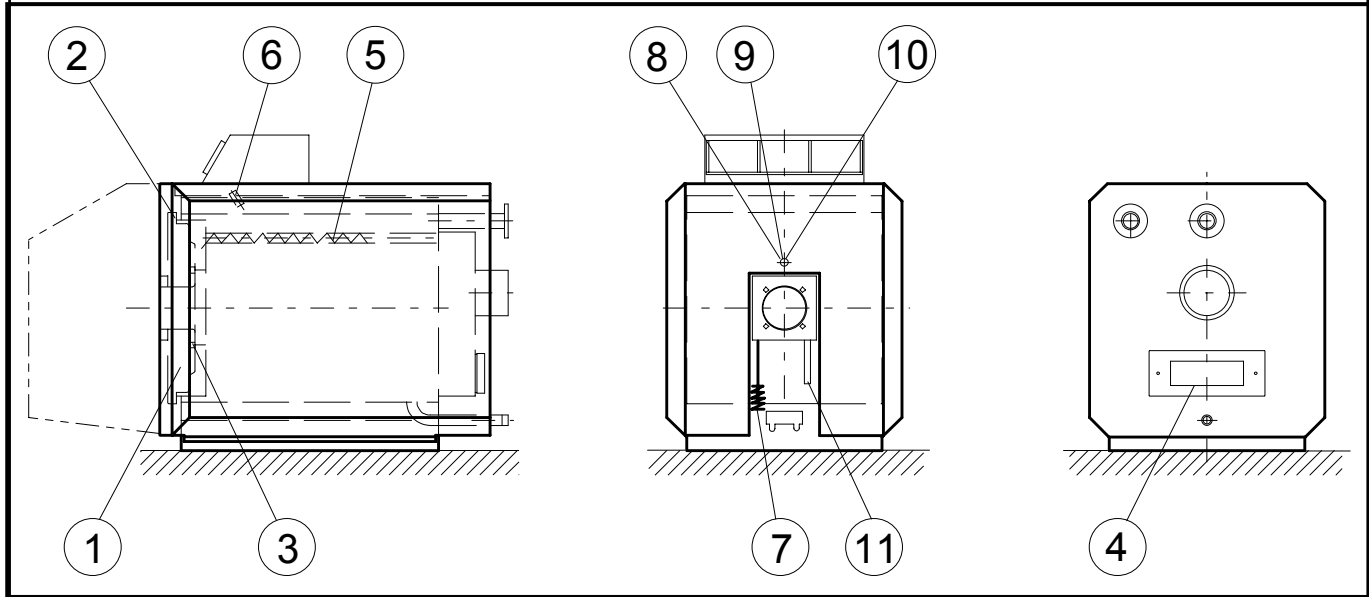
### **12.2 Temperature Limiter (Limit Thermostat)**

The temperature limiter replacement procedure follows that of the control thermostat with some minor differences as detailed below:

With the plastic cover removed, unscrew the holding nut and carefully withdraw the thermostat body. Prior to fitting the replacement thermostat, set to 100°C and check the operation of the device by carefully applying a heat source to the bulb.

**15. SPARE PARTS LIST**

**15.1 Boiler Spares**



**Figure 12.1 – Spares identification**

ENSBURY LT model	70	90	120	145	165	190	225	260	300	335	370	440	510	580														
<b>No.</b>	<b>Description</b>														<b>HHL Part Number</b>													
1	Door insulation moulding		573410213	573410214	573410214	573410215	573410216	573410217																				
2	Door outer seal 25 * 25 * L mm		573401218	573410219	573410219	573410220	573410221	573410222																				
3	Door outer seal 25 * 25 * L mm		573410223	573410224	573410224	573410225	573410226	573410227																				
4	Flue hood inspection panel seal 10Ø * L mm		573410228																									
5	Turbulator Number off		573410229 9	573410230 9	573410230 11	573410231 11	573410230 11	573410231 11	573410231 15	573410229 15	573410230 15	573410230 19	573410231 19	573410229 25	573410230 25	573410232 25												
6	Thermostat channel		573410233																									
7	Brush		573410234																									
8	Nut for inspection window G 3/4"		573410235																									
9	Inspection window Ø 23 x 4		573410236																									
10	Inspection window Seal Ø 24/20 x 1		573410237																									
11	Door key		573410238						573410239																			

**Figure 12.2 Control Panel Spares - refer to figure 8.2**

ITEM	DESCRIPTION	PART NO.
1	Thermometer .....	573410251
2	Burner On/Off switch .....	573410241
3 & 7	Safety cut out test or remote reset button .....	573410242
4,5 & 6	Alarm lamp (red) .....	573410243
8.	Fuse 6.3AT .....	573410245
9.	Limit thermostat .....	573410247
10 & 11.	Control thermostat .....	573410249
12	Hours run meter .....	573410252
	Fuse holder .....	573410244
	Auxiliary relay 11 pole .....	573410248



## APPENDIX A - PERFORMANCE DATA

BOILER MODEL - ENSBURY LT		70	90	120	145	165	190	225	260	300	335	370	440	510	580
<b>GENERAL DATA</b>															
BOILER INPUT(net) - maximum	kW	77	99	132	159	181	209	247	286	330	368	407	483	560	637
BOILER INPUT(gross) - maximum	kW	85	110	146	177	201	232	274	317	366	409	451	537	622	707
BOILER OUTPUT - maximum	kW	70	90	120	145	165	190	225	260	300	335	370	440	510	580
BOILER OUTPUT - minimum	kW	25	50	50	50	50	60	60	60	87	87	87	100	100	165
<b>FLUE DATA</b>															
NOMINAL FLUE DIA.	mm	150						200				250			
COMBUSTION CHAMBER RESISTANCE	mbar	0.45	0.84	1.00	1.64	1.81	2.69	2.21	2.31	3.50	2.88	3.88	2.53	3.83	5.86
APPROX. FLUE GAS TEMP - (gross)	°C	177	188	176	188	184	193	189	191	202	192	198	182	192	197
APPROX. FLUE GAS VOLUME @ NTP 15°C 9% CO <sub>2</sub>	m <sup>3</sup> /h	92	123	154	215	241	271	301	361	430	461	523	615	707	830
<b>GAS DATA</b>															
NOMINAL GAS INLET PRESSURE	mbar	20													
MAX. GAS INLET PRESSURE FOR BOOSTED SUPPLIES	mbar	50													
GAS FLOW RATE	m <sup>3</sup> /h	8.1	10.5	14.0	16.9	19.2	22.1	26.2	30.2	34.9	39.0	43.0	51.2	59.3	67.4
GAS INLET CONNECTION		3/4"				1-1/4"				1-1/2"			2"	1-1/2"	2"

**Figure A.1 – Performance and General Data Information (Natural Gas)**

**Note:** For matched burner/boiler combinations, refer to Figures 11.1, 11.2 & 11.3

For combustion target figures, refer to Figure 11.5

For data relating to Propane and Oil refer to Appendices A2 & A3.

Net CV 34.02 MJ/m<sup>3</sup> - Gross CV 37.8 MJ/m<sup>3</sup>

BOILER MODEL - ENSBURY LT		70	90	120	145	165	190	225	260	300	335	370	440	510	580	
<b>GENERAL DATA</b>																
BOILER INPUT(net) - maximum	kW	79	101	135	163	185	213	253	292	337	376	416	494	573	651	
BOILER INPUT(gross) - maximum	kW	85	110	146	177	201	232	274	317	366	409	451	537	622	707	
BOILER OUTPUT - maximum	kW	70	90	120	145	165	190	225	260	300	335	370	440	510	580	
BOILER OUTPUT - minimum	kW	25	50	50	50	50	60	60	60	87	87	87	100	100	165	
<b>FLUE DATA</b>																
COMBUSTION CHAMBER RESISTANCE	mbar	0.45	0.84	1.00	1.64	1.81	2.69	2.21	2.31	3.50	2.88	3.88	2.53	3.83	5.86	
APPROX. FLUE GAS TEMP - (gross)	°C	177	188	176	188	184	193	189	191	202	192	198	182	192	197	
APPROX. FLUE GAS VOLUME @ NTP 15°C 9% CO <sub>2</sub>	m <sup>3</sup> /h	92	123	154	215	241	271	301	361	430	461	523	615	707	830	
<b>GAS DATA</b>																
NOMINAL GAS INLET PRESSURE	mbar	37														
GAS FLOW RATE	m <sup>3</sup> /h	3.2	4.1	5.5	6.7	7.6	8.7	10.3	11.9	13.8	15.4	17.0	20.2	23.4	26.6	
GAS INLET CONNECTION		3/4"				1-1/4"						1-1/2"				

**Figure A.2 – Performance and General Data Information (LPG Propane)**

**Note:** For matched burner/boiler combinations, refer to Figures 11.1, 11.2, 11.3 & 11.4

For combustion target figures, refer to Figure 11.5

Net CV 88.0 MJ/m<sup>3</sup> - Gross CV 95.6 MJ/m<sup>3</sup>

BOILER MODEL - ENSBURY LT		70	90	120	145	165	190	225	260	300	335	370	440	510	580
<b>GENERAL DATA</b>															
BOILER INPUT(net) - maximum	kW	80	102	136	165	188	216	256	296	341	381	421	500	580	659
BOILER INPUT(gross) - maximum	kW	85	110	146	177	201	232	274	317	366	409	451	537	622	707
BOILER OUTPUT - maximum	kW	70	90	120	145	165	190	225	260	300	335	370	440	510	580
BOILER OUTPUT - minimum	kW	38	61	61	61	83	83	83	83	133	133	133	127	127	219
<b>FLUE DATA</b>															
COMBUSTION CHAMBER RESISTANCE	mbar	0.45	0.84	1.00	1.64	1.81	2.69	2.21	2.31	3.50	2.88	3.88	2.53	3.83	5.86
APPROX. FLUE GAS TEMP - (gross)	°C	177	188	176	188	184	193	189	191	202	192	198	182	192	197
APPROX. FLUE GAS VOLUME @ NTP 15°C 9% CO <sub>2</sub>	m <sup>3</sup> /h	92	123	154	215	241	271	301	361	430	461	523	615	707	830
<b>GAS DATA</b>															
OIL FLOW RATE	L/h	8.1	10.4	13.8	16.7	19.0	21.9	26.0	30.0	34.6	38.6	42.7	50.8	58.8	66.9

**Figure A.3 – Performance and General Data Information (Fuel Oil– class D 35 sec)**

**Note:** For matched burner/boiler combinations, refer to Figures 11.1, 11.2 & 11.3  
For combustion target figures, refer to Figure 11.5  
Net CV 42.66 MJ/ kg - Gross CV 45.36 MJ/kg

## APPENDIX B - ELECTRICAL CONNECTIONS AND CONTROLS

### B.1. Electrical Connections:

The following electrical connections are provided on each boiler panel.

- Supply: Live, Neutral and Earth. (230V ~50Hz) See Section 4.5 for details.
- Burner Lockout Alarm Signal Output  
- volt free
- Burner Low Fire Signal Output - volt free
- Burner High Fire Signal Output - volt free
- Boiler Overheat Lockout Alarm Signal Output - volt free
- External Interlock Alarm Signal Output  
- volt free
- Remote on/off Control Input
- Safety Interlock Circuit Input
- Emergency On/Off Button

**Note:** All wiring and electrical connections must be completed by a competent person in accordance with current IEE regulations.

Power supply required is 400V 50 Hz three phase, 4 wire. An isolator correctly fused should be sited close to the boiler. Refer to the burner instructions.

**It should be noted the 3 phase supply should be wired direct to the burner and a separate 240V single phase supply derived from the burner should be wired to the panel.**

**Note:** If a modulating burner is fitted to the boiler, some alterations to the wiring will be necessary. The burner manufacturer's instructions must be followed. It is likely that the second stage wiring (flying lead with four pin plug, hi/lo thermostat etc.) will become redundant and additional temperature sensor(s) will need to be added.

**Warning:** On no account must the route of the cables allow them to contact any unprotected or un-insulated surface. For example; the burner mounting plate

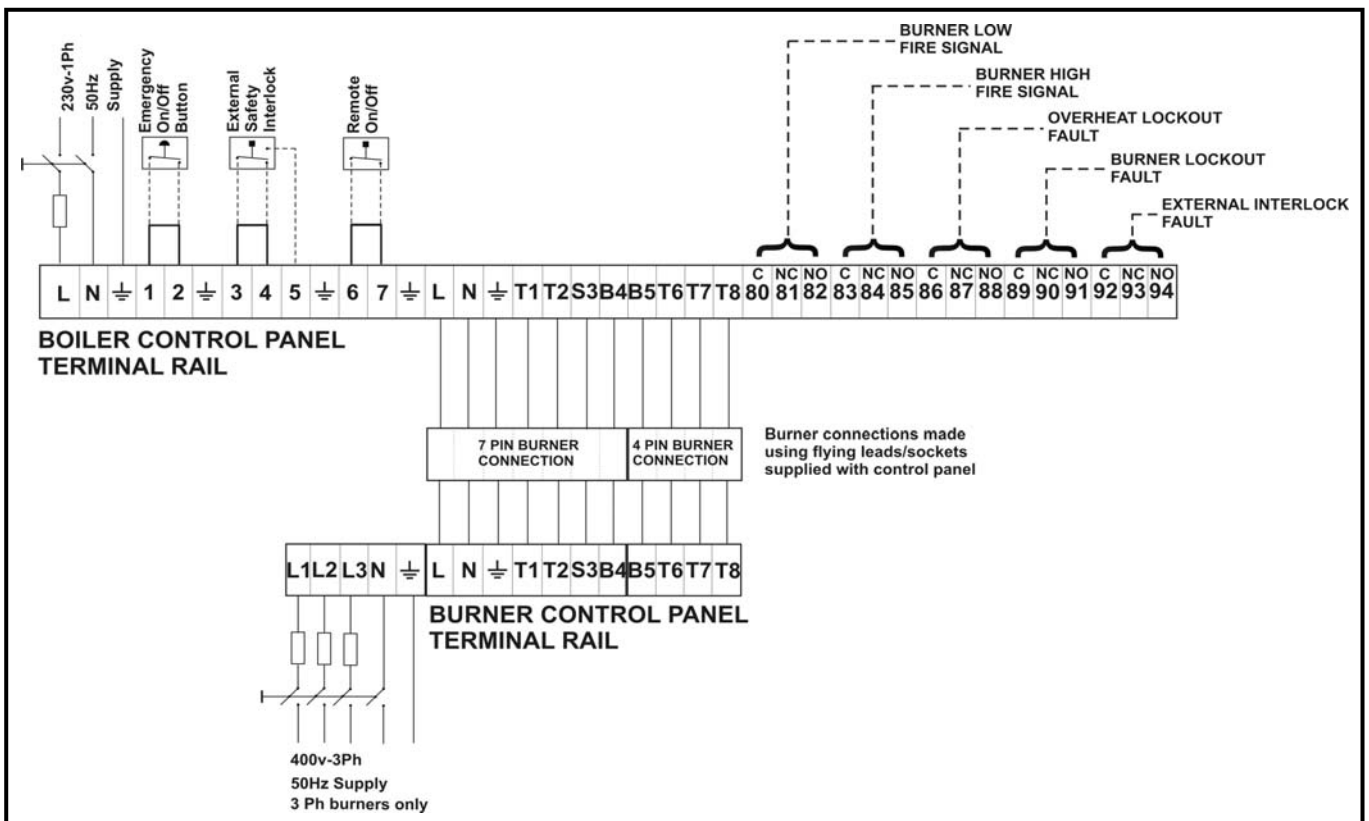


Figure B.1 - Electrical connections

## **APPENDIX C - FLUE DATA**

### **C 1 General Requirements**

Detailed recommendations for flue systems are given in **BS 6644, IGE/UP/10**, "Flues for Commercial and Industrial Gas-Fired Boilers and Air Heaters."

The following notes are intended to give general guidance only.

The flue passages within the Ensbury LT operate under pressurised conditions and in order to eliminate any additional resistance, it is recommended that the flue system shall be adapted to its design diameter as soon as possible, after leaving the boiler.

The boiler should be connected to a single flue system in the case of a single boiler, or a common flue header in the case of a multiple boiler installation. Flue systems must be self supporting, contain access for cleaning and contain a maintenance joint near the boiler outlet to allow for removal of the flue box during servicing.

Ensbury LT boilers are suitable for installation in a balanced compartment in accordance with the requirements of **BS 6644**. Consult Hamworthy Heating Technical Department for help or assistance if in doubt.

### **C.2 Design Waste Gas Volume and Temperature**

It is recommended that the volume and temperature of the waste gases used for design of the flue system are as shown in Figures A1, A2 & A3

### **C.3 Materials**

Materials used for the flue system must be mechanically robust, resistant to internal and external corrosion, non-combustible and durable under the conditions to which they are likely to be subjected.

Consideration should be given to possible freezing of condense water traps and pipework. This must be avoided at all times. Insulate condense pipes if freezing temperatures are likely to be encountered.

Chimneys should be lined with a non-porous acid-resistant material in accordance with BS.5854, e.g. a flexible flue liner or similar British Gas Approved material. The internal diameter of the liner must not be less than the recommended flue size and the number of joints should be kept to a minimum.

Any joint between the flexible liner and the flue pipe from the boiler should be made using a purpose made connector. Existing chimneys should be thoroughly swept before use and any register plates, dampers, or restrictions removed.

If the boiler(s) is not connected to a chimney system, but is connected directly to outside by a standard stainless steel flue (either single or twin wall) it is particularly important to ensure that the point at which it exits the building is fully weatherproofed.

### **C.4 Suction**

The flue system should be designed to maintain atmospheric pressure or a slight suction at the boiler flue connection at all times (0.1 - 0.3mbar).

It is recommended that a draught stabiliser is fitted to the flue system where the suction is likely to exceed 0.3mbar.

### **C.5 Disconnection**

Provisions should be made for disconnection of the flue pipe for servicing. It is advisable that bends are fitted with removable covers for inspection and cleaning as appropriate. **NOTE!** The flue system must be self supporting and not present a risk to people in or around the building.

See **Section 13: SERVICING** for further information.

### **C.6 Flue Discharge**

The flue system must ensure safe and efficient operation of the boiler to which it is attached, protect the combustion process from wind effects and disperse the products of combustion to the external air.

The flue must terminate in a freely exposed position and be situated so as to prevent the products of combustion entering any opening in a building. Consideration should be given to the fitting of a flue discharge terminal or grille to stop the ingress of birds etc.

The flue system should be designed such that the flue terminates at least 1 metre above the roof surface, or above the level of any nearby structure which is within 2.5 metres of the flue.

### **C.7 Surface Temperatures**

Combustible materials in the vicinity of the boiler and flue shall not exceed 65 °C during boiler operation. The flue shall not be closer than 50mm to any combustible material, except where it passes through such material with a non-combustible sleeve when the air gap may not be less than 25mm.

### **C.8 Flue System Location**

The flue system must not be placed or fitted where there is undue risk of accidental damage to the flue pipe or undue danger to persons in the vicinity. **NOTE!** The flue **MUST** be self supporting. Check that the flue and chimney are clear from any obstruction.

### **C.9 Condensate Discharge**

When designing the flue system, care must be taken to ensure that any condensate which may form within the system, can be safely drained to a suitable waste point and, that the flue material used is resistant to the corrosive effects of that condensate.

## **APPENDIX D - VENTILATION**

### **D1.1 Air Supply**

Detailed recommendations for air supply are given in BS 6644 and BS5440 Pt 2. The following notes are intended to give general guidance. In all cases there must be provision for an adequate supply of air for both combustion and general ventilation, in addition to that required for any other appliance.

### **D1.2 Air Supply by Natural Ventilation - Open Flue applications**

The boiler room must have, or be provided with, permanent air vents directly to the outside air, at high level and at low level. For an exposed boiler house, air vents should be fitted, preferably on all four sides, but at the least on two sides. Air vents should have negligible resistance and must not be sited in any position where they are likely to be easily blocked or flooded or in any position adjacent to an extraction system which is carrying flammable vapour. Grilles or louvres must be so designed that high velocity air streams do not occur within the space housing the boiler.

#### **Boiler house ventilation**

Low level (inlet) - 4cm<sup>2</sup> per kW of total rated input (Net)  
High level (output) - 2cm<sup>2</sup> per kW of total rated input (Net)

#### **Compartment ventilation**

Where the boiler is to be installed in a compartment, permanent high and low level ventilation is required which must communicate direct to outside, for cooling purposes.

Low level (inlet) - 10cm<sup>2</sup> per kW of total rated input (Net)  
High level (output) - 5cm<sup>2</sup> per kW of total rated input (Net)

### **D1.3. Air Supply by Mechanical Ventilation**

Air supplied to the boiler room by Mechanical means should be as follows:

- 1) Mechanical ventilation must be interlocked with the boilers to prevent operation in the event of ventilation fan failure
- 2) Mechanical inlet and mechanical extract can be utilised providing the design extraction rate does not exceed one third of the design inlet rate.
- 3) Mechanical extract ventilation with natural inlet ventilation **MUST NOT** be used.

For Mechanical ventilation systems an automatic control should be provided to cut off the gas supply to the boiler, in the event of failure of air flow in either inlet or extract fans.

### **D 1.4. Boiler House Temperatures**

The air supplied for boiler house ventilation shall be such that the maximum temperatures within the boiler house shall be as follows:

At floor level (or 100mm above floor level) = 25°C.

At mid-level (1.5m above floor level) = 32°C.

At ceiling level (or 100mm below ceiling level) = 40°C.

### **D 1.5. General Requirements**

The air supply should be free from contamination such as building dust and insulation fibres from lagging. To avoid unnecessary cleaning and servicing of the boiler modules, the boilers should not be fired whilst building work is being undertaken. High and low level ventilation grilles shall be positioned as high and as low as practicably possible. Low level grilles should be located within 1 metre of the floor for Natural Gas and within 250mm of the floor for LPG. High level grilles should be positioned within 15% of the boiler room height from the ceiling. High and low level grilles shall communicate with the same room or space where compartment ventilation is used. Where grilles communicate directly with outside air, they shall be positioned on the same wall.

**Figure D1 Mechanical Ventilation Flow Rates**

	Flow rate per kW total rated heat input (Net)	
	Inlet air (Combustion ventilation)	Difference between Inlet & Extract air *
	m <sup>3</sup> /h.	m <sup>3</sup> /h.
Volume	2.6	1.35

**Note \*** : Where the associated air extraction is also by means of a fan, this shall be selected such as not to cause a negative pressure to develop in the boiler house and to maintain the difference between inlet and extract flow rates shown above.

The calculated extract flow rate is the actual inlet flow rate minus the appropriate figure in the table above.

## APPENDIX E - WATER DATA

Ensbury LT	70	90	120	145	165	190	225	260	300	335	370	440	510	580
Hydraulic resistance @ ΔT 10°C – mbar	43	71	40	58	76	100	48	66	87	108	132	81	108	140
Hydraulic resistance @ ΔT 20°C – mbar	11	18	10	15	19	25	12	17	22	27	33	20	27	35
Water flow rate maximum - m <sup>3</sup> /h	6.0	7.7	10.3	12.3	14.2	16.3	19.3	22.3	25.8	28.8	31.8	37.8	43.8	49.8
Water flow rate minimum	No minimum flow rate													
Water pressure - maximum barg	4													
Water pressure - minimum barg	0.5													
Water flow temperature - maximum °C	90													
Water flow temperature - minimum (gas) °C	60													
Water flow temperature - minimum (oil) °C	50													
Water return temperature - minimum °C														
Water connections - flow & return (flange)	1 1/2"	PN6 - DN50				PN6 - DN65				PN6 - DN80				
Safety valve connection	3/4"	1"				1-1/4"				1-1/2"				
Drain connection	1"													
Water content - litres	130	130	185	185	220	220	260	315	315	360	360	540	540	540
Weight empty - without burner	283	284	393	394	447	448	522	606	607	737	739	973	976	980

**Figure E.1 - Water data**

### E 1 Water circulation system

Recommendations for the water circulation system are given in **BS 6644** for gas fired boilers but the same principals can be used for those using fuel oil. The following notes are of particular importance:-

**E1.1** In a combined central heating and hot water system, the hot water storage vessel must be of the indirect cylinder or calorifier type. The hot water storage vessel should be insulated preferably with not less than 75mm (3 in) thick mineral fibre, or its thermal equivalent.

**E1.2** Circulating pipework not forming part of the useful heating surface should be insulated to help prevent heat loss and possible freezing, particularly where pipes are run through roof spaces and ventilated cavities. Cisterns situated in areas, which may be exposed to freezing conditions, should also be insulated. Insulation exposed to the weather should be rendered waterproof.

**E1.3** Each boiler has flanged flow and return connections located on the rear section of the boiler.

**E1.4** Multiple boilers should be connected by flow and return headers. Headers should be connected to the system in a "reverse return" arrangement (the water flow in each header is in the same direction) to ensure equal flow in each boiler.

**E1.5** E1.5 A coarse filter and dirt separator **MUST** be fitted in the return to both primary and secondary heat exchangers

### E.2 Pressure Relief Valve (Safety Valve)

The most important single safety device fitted to a boiler is its safety valve and each boiler, or in the case of a multiple installation, each bank of boilers,

must be fitted with a pressure relief valve to **BSEN-**

**ISO 4126-1** and sized as shown in **BS 6644**.

Each Ensbury LT has a tapping on the flow pipe for the fitting of a safety valve to the boiler.

**BS 6644** provides comprehensive information for the selection and location of safety valves and attention is drawn to the higher capacity requirements of safety valves for pressurised hot water systems.

### E.3 Open Vent and Cold Feed Pipe

(See **BS 6644** for further information.)

Every boiler or group of boilers should have an open vent pipe and cold feed pipe installed between the boiler and the first water isolating valve. The minimum bore (mm) of these pipes per installation is shown in figure E.2.

The vent pipe must rise continually, must not be valved except by a design which when closed for maintenance the boiler is open to atmosphere. The pipe shall be protected against freezing where this might occur.

### 7.4 Altitude Gauge (Water Pressure Gauge)

Every boiler or group of boilers should be provided with a gauge complete with isolating valve. See Figure E.3 for typical position.

### 7.5 Thermometer

A thermometer complete with pocket should be fitted in the pipework to indicate water flow temperature. See Figure E.3 for typical position.

### 7.6 Drain Valves

Each boiler should have a drain valve fitted (not

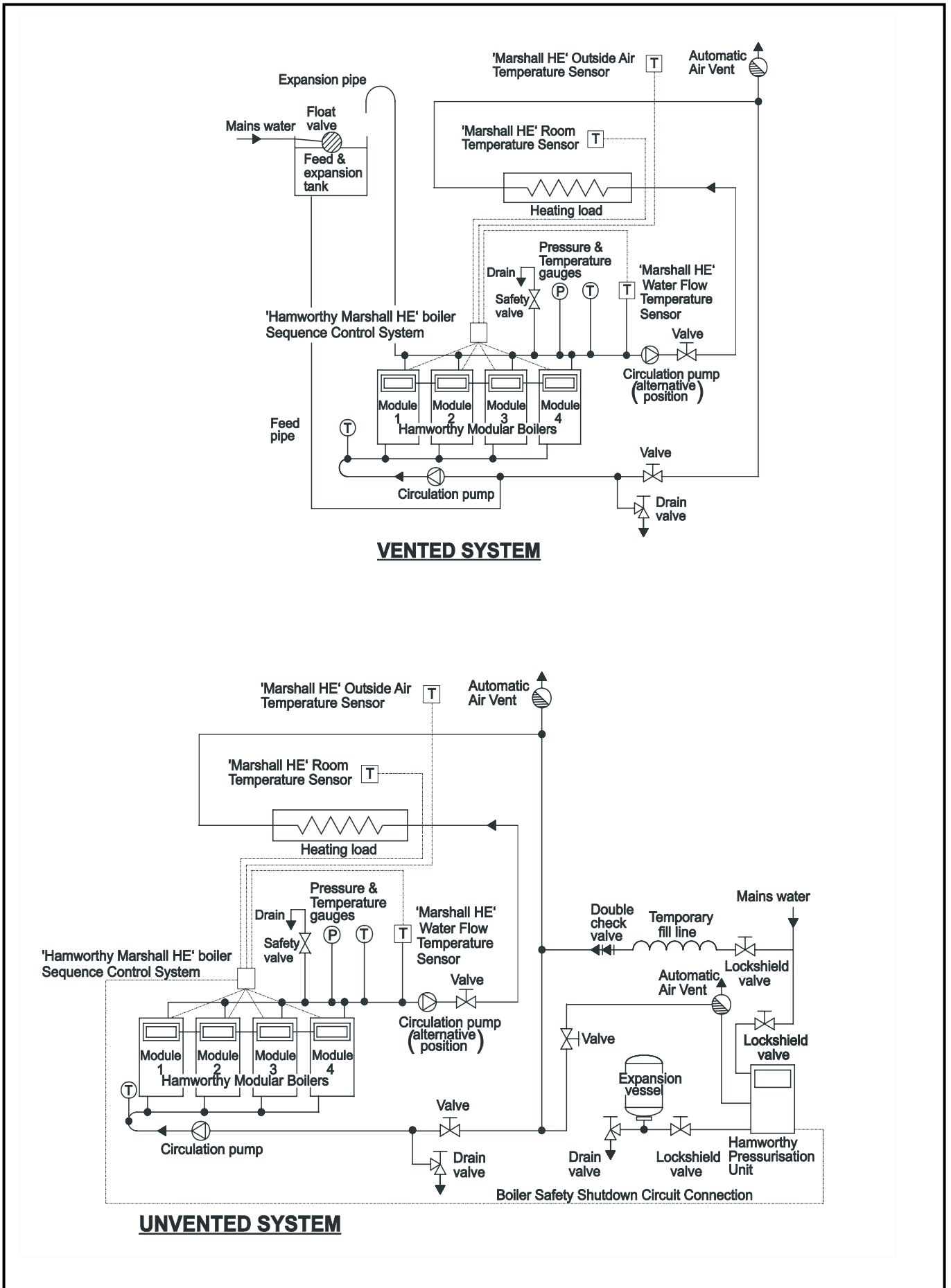


Figure E.2. Typical Boiler Installation

H.H.L. supply), to drain the boiler only. An plugged Rc½ connection is provided for a drain valve on the flanged return connection.

The heating system in total should have drain valves as recommended by **BS 6644** which permit the draining of the whole system, including the boiler and any hot water storage vessel. See Figure 3.3 for recommended positions.

### 7.7 Circulating Pump

One or more circulating pumps will be required to

circulate water around the boilers and heating system. The pump should be sited to facilitate servicing.

### 7.9 Waterside Pressure Drop

The waterside hydraulic resistance (Pressure drop) is shown in Figure E1.

Boiler Output	Feed	Vent
60kW - 150kW	25	32
150kW – 300kW	32	38
300kW – 600kW	38	50

Figure E.3 - Cold Feed and Vent Pipe Sizes (mm)

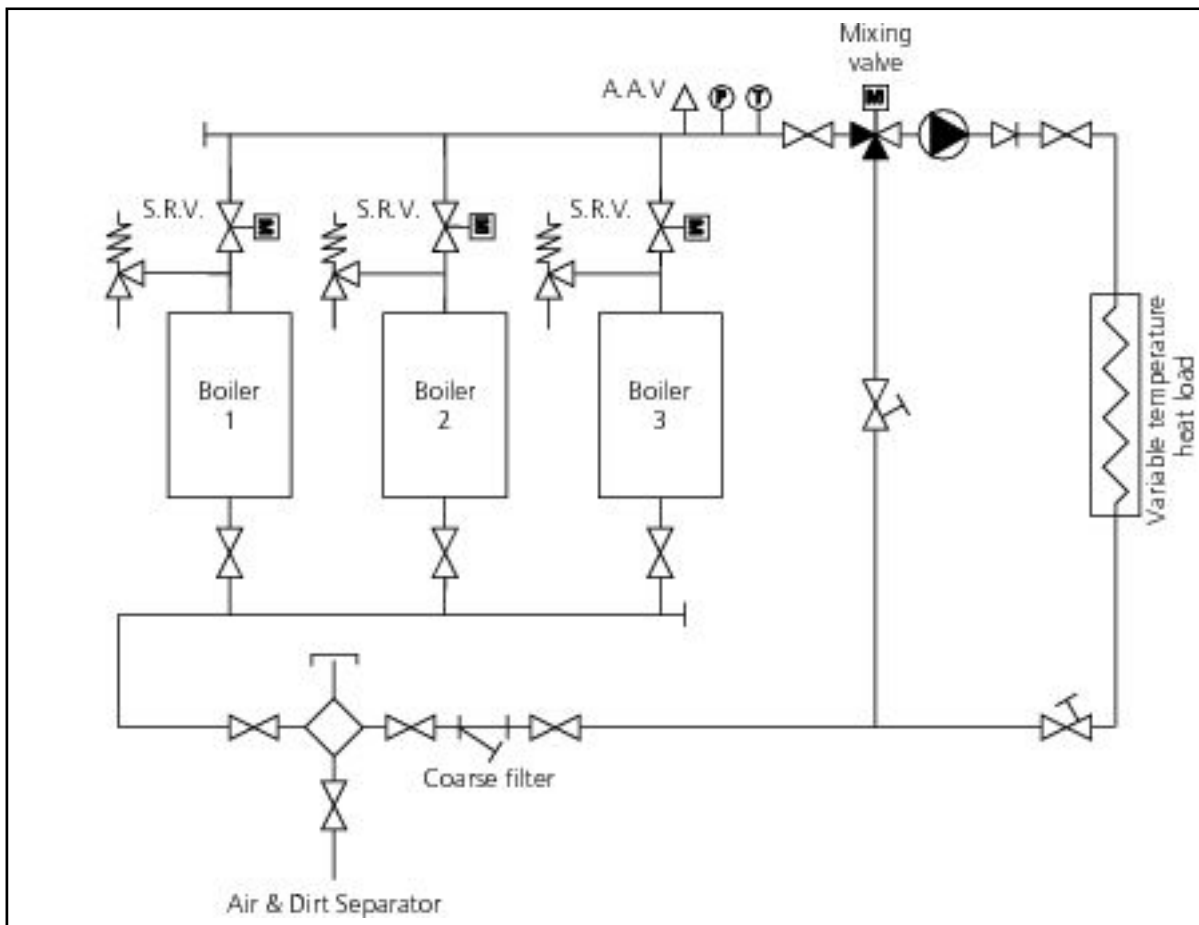
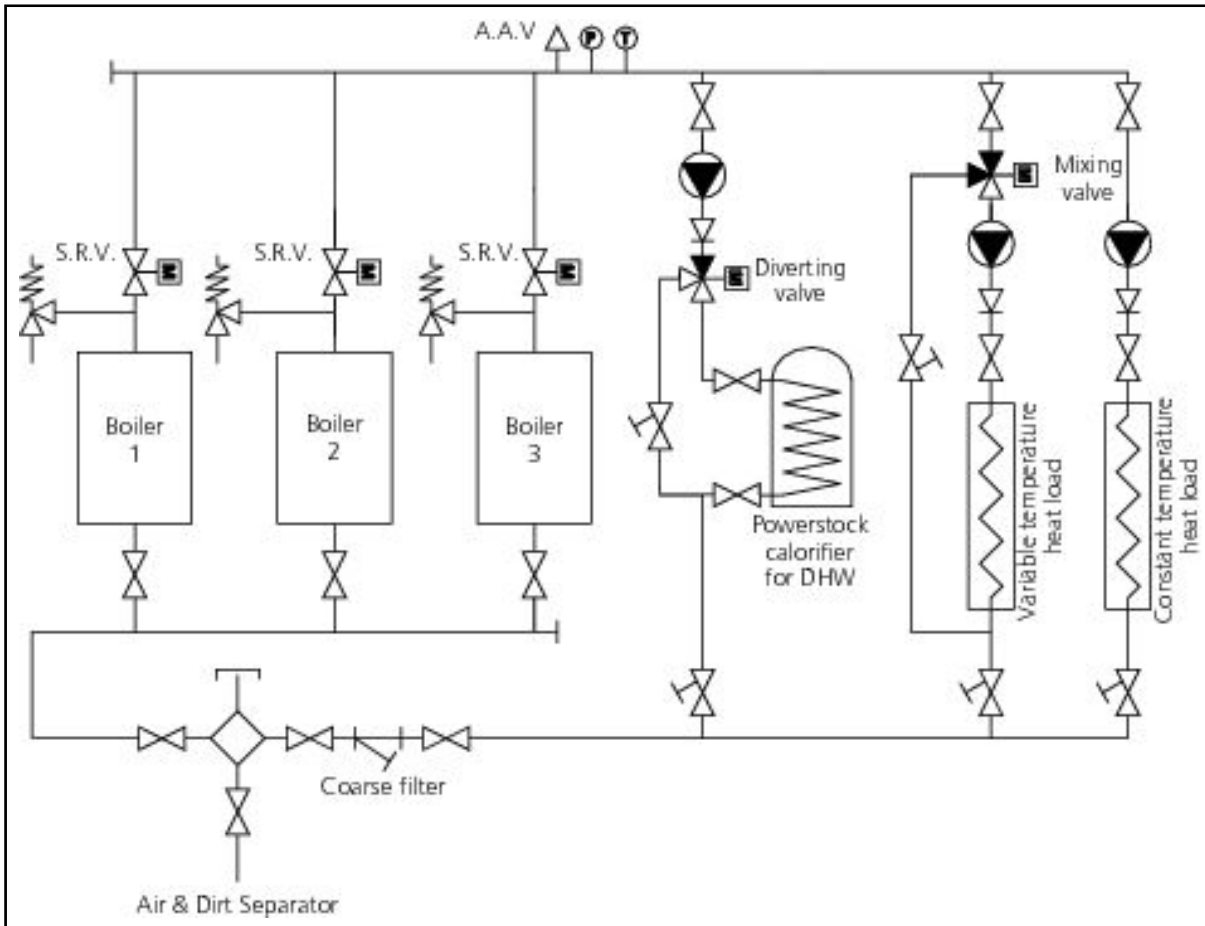


Figure E.4. Boiler Installation with Variable Temperature Heating Circuit

Compensation of the heating circuit must use an external mixing control and the minimum allowable flow temperature must be maintained.





**Figure E.5. Boiler Installation with Constant and Variable Temperature Heating Circuits With Domestic Hot Water**

Compensation of the variable temperature heating circuit must use an external mixing control. Boiler operating temperatures should be set to meet the demands of the highest temperature circuit, but not set below the minimum boiler flow temperature. Where all circuits are required to operate below the minimum boiler flow temperature, then all circuits should incorporate mixing controls, to lower the temperature from the boiler before distribution to the circuit. Due to the thermal mass and water content of the boiler body, the temperature of the heating circuit return can be low. For minimum temperature details refer to figure E1

**USEFUL USER INFORMATION**

<b>INSTALLER</b>		<b>SITE ADDRESS</b>		

<b>BOILER TYPE</b>	<b>BOILER SIZE(S)</b>	<b>UNIT NO(S).</b>	<b>SERIAL NO(S).</b>	<b>FLUE</b>

# Notes

A large empty rectangular box with a thin black border, intended for taking notes. There are small decorative icons in the top-right and bottom-left corners of the box.

# Hamworthy Heating Accredited Agents

## **North West England**

Gillies Modular Services  
210-218 New Chester Road, Birkenhead, Merseyside L41 9BG  
tel: **0151 666 1030** fax: **0151 647 8101**

## **Southern Ireland**

HEVAC Limited  
Naas Road, Dublin 12, Ireland  
tel: **00 353 141 91919** fax: **00 353 145 84806**

## **Northern Ireland**

HVAC Supplies Limited  
Unit 12 forty 8 north, 48 Duncrue Street, Belfast BT3 9BJ  
tel: **02890 747737** fax: **02890 741233**

## **Scotland**

McDowall Modular Services  
14-46 Lomond Street, Glasgow, Scotland G22 6JD  
tel: **0141 336 8795** fax: **0141 336 8954**

## **North East England**

Allison Heating Products  
12 Sunnyside Lane, Cleadon Village, Sunderland SR6 7XB  
tel: **0191 536 8833** fax: **0191 536 9933**



## **Customer Service Centre**

Hamworthy Heating Limited,  
Fleets Corner, Poole,  
Dorset BH17 0HH

Telephone: **0845 450 2866**

Fax: **01202 662522**

Email: [aftersales@hamworthy-heating.com](mailto:aftersales@hamworthy-heating.com)

Website: [www.hamworthy-heating.com](http://www.hamworthy-heating.com)