

- I** **Bruciatore di kerosene e gasolio**
- GB** **Kerosene and gas oil burner**
- F** **Brûleur kérosène et fioul domestique**
- D** **Kerosin und Öl-Gebläsebrenner**
- E** **Quemador de queroseno y gasóleo**

Funzionamento monostadio
One stage operation
Fonctionnement à 1 allure
Einstufiger Betrieb
Funcionamiento de una sola llama

CODICE - CODE CÓDIGO	MODELLO - MODEL - MODELE MODELL - MODELO	TIPO - TYPE - TYP
3747469	G20	474T51

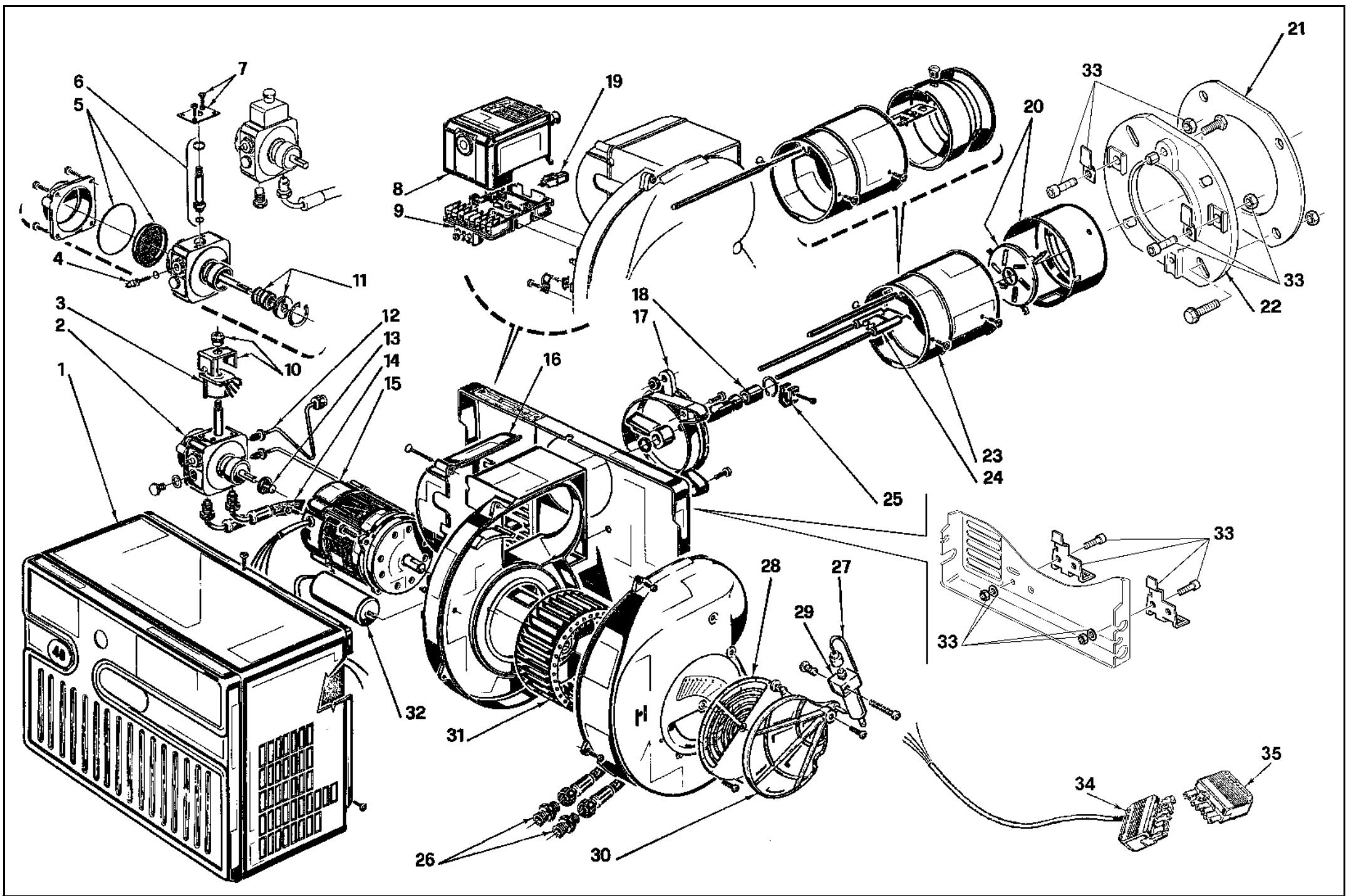

N.	COD.	DESCRIZIONE	DESCRIPTION	DESCRIPTION	BESCHREIBUNG	DENOMINACION	MATRICOLA BRUCIATORE BURNER SERIAL NUMBER MATRICULE BRULEUR BRENNER KENN-NUMMER MATRICULA QUEMADORES	*
1	3007235	COFANO	COVER	COFFRET	VERKLEIDUNG	ENVOLVENTE		
2	20031996	POMPA	PUMP	POMPE	ÖLPUMPE	BOMBA		C
3	3002279	BOBINA	COIL	BOBINE	SPULE	BOBINA		B
4	3007202	REGOLATORE PRESSIONE POMPA	PUMP PRESSURE REGULATOR	REGULATEUR PRESSION POMPE	DRUCKREGULIERSCHRAUBE	REGULADOR PRESIÓN BOMBA		B
5	3020436	FILTRO – ANELLO OR	FILTER – O-RING	FILTRE – JOINT TORIQUE	FILTEREINSATZ – O-RING- DICHTUNG	FILTRO – JUNTA TÓRICA		A
6	3020437	VALVOLA	NEEDLE VALVE	VANNE	MAGNETVENTIL-KÖPER	VÁLVULA		B
7	3007203	PIASTRINA	PLATE	PLAQUETTE ETRIER	PLATTE	PLATINA		
8	3001156	APPARECCHIATURA	CONTROL BOX	BOITE DE CONTROLE	STEUERGERÄT	CAJA DE CONTROL		B
9	3002278	MORSETTIERA	TERMINAL BOARD	BORNIER	STECKSOCKEL	REGLETA DE CONEXIÓN		
10	3006553	MANTELLO E POMELLO	SHELL AND KNOB	ETRIER ET ECROU	HALTEBÜGEL MIT SCHRAUBE	PROTECCIÓN BOBINA		B
11	3020443	ORGANO DI TENUTA	PUMP SEAL	ORGANE D'ETANCHEITE	DICHTUNGSEINSATZ ANTRIEBSWELLE	CONJUNTO ESTANQUIDAD		A
12	3005819	TUBO	TUBE	TUYAU	DRUCKROHR	TUBO		
13	3000443	GIUNTO	JOINT	ACCOUPEMENT	PUMPENKUPPLUNG	ACOPLAMIENTO		A
14	20022601	TUBO FLESSIBILE	HOSE	TUYAU FLEXIBLE	ÖLSCHLAUCH	TUBO FLEXIBLE		A
15	3005820	MOTORE	MOTOR	MOTEUR	MOTOR	MOTOR		C
16	3006558	COPERCHIO	COVER	COUVERCLE	DÜSENSTOCK-FLANSCH	TAPA		
17	3005810	COLLARE	COLLAR	COLLIER	BRENNERFLANSCH	COLLARÍN		
18	3005764	PORTAUGELLO	NOZZLE HOLDER	PORTE-GICLEUR	DÜSENSTOCK	PORTABOQUILLA		C
19	20132573	SENSORE FIAMMA	FLAME SENSOR	CAPTEUR FLAMME	FLAMMENFÜHLER	SENSOR LLAMA		A
20	3006264	ANELLO - ELICA	END RING AND DIFFUSER DISC	EMBOUT GUEULARD + ACCROCHE FLAMME	FLAMMKOPF+STAUSCHEIBE	ANILLO LLAMA - DISCO ESTABILIZADOR		A
21	3005813	SCHERMO	GASKET	JOINT ISOLANT	KESSELFLANSCH-DICHTUNG	JUNTA AISLANTE		A
22	3005814	FLANGIA	FLANGE	BRIDE	KESSELFLANSCH	BRIDA		
23	3006265	GRUPPO BOCCAGLIO	BLAST TUBE ASSEMBLY	GROUPE GUEULARD	BRENNERROHR SYSTEM	CONJUNTO TUBO LLAMA		
24	3002919	GRUPPO ELETTRODI	ELECTRODE ASSEMBLY	GROUPE ELECTRODES	ELEKTRODENBLOCK	CONJUNTO ELECTRODOS		A
25	3006552	FASCETTA	ELECTRODE BRACKET	SUPPORT ELECTRODES	ELECTRODEN HALTERUNG	SOPORTE ELECTRODOS		
26	3009068	RACCORDO	CONNECTOR	MAMELON	ANSCHLUßNIPPEL	RACORD		A
27	3007816	TUBO	TUBE	TUYAU	DRUCKROHR	TUBO		
28	3007206	SERRANDA ARIA	AIR DAMPER	VOLET D'AIR	LUFTKLAPPE	REGISTRO DEL AIRE		
29	3020500	MARTINETTO	HYDRAULIC JACK	VERIN AIR	DRUCKKOLBEN FÜR LUFTKLAPPE	HIDRAULICO DE AIRE	≤ 01273XXXXXX	C
29	3006911	MARTINETTO	HYDRAULIC JACK	VERIN AIR	DRUCKKOLBEN FÜR LUFTKLAPPE	HIDRAULICO DE AIRE	≥ 01283XXXXXX	C
30	3000880	SERRANDA ARIA	AIR DAMPER	VOLET D'AIR	LUFTKLAPPE	REGISTRO DEL AIRE		
31	3005799	GIRANTE	FAN	TURBINE	GEBLÄSERAD	TURBINA		C
32	20087026	CONDENSATORE	CAPACITOR	CONDENSATEUR	KONDENSATOR	CONDENSADOR		C
33	3020407	GRUPPO MANUTENZIONE	MAINTENANCE ASSEMBLY	GROUPE ENTRETIEN	WARTUNGSYSTEM	CONJUNTO MANTENIMIENTO		A
34	3006386	PRESA 7 POLI	7 POLE SOCKET	PRISE À 7 PÔLES	7-POLIGE STECKDOSE	CONECTOR HEMBRA DE 7 CONTACTOS		C

N.	COD.	DESCRIZIONE	DESCRIPTION	DESCRIPTION	BESCHREIBUNG	DENOMINACION	MATRICOLA BRUCIATORE BURNER SERIAL NUMBER MATRICULE BRULEUR BRENNER KENN-NUMMER MATRICULA QUEMADÓRES	*
35	3006937	SPINA 7 POLI	7 PIN PLUG	FICHE 7 PÔLES	7-POLIGER STECKER	CONECTOR MACHO DE 7 CONTACTOS		A

★

RICAMBI CONSIGLIATI - ADVISED PARTS - RECHANGE CONSEIL - EMPFOHLENE ERSATZTEILE - RECAMBIOS ACONSEJADOS

A = Ricambi per dotazione minima - Spare parts for minimum fittings - Pièces détachées pour équipement minimum - Ersatzteile für minimale Ausstattung - Recambios para equipamiento mínimo

A+B = Ricambi per dotazione base di sicurezza - Spare parts for basic safety fittings - Pièces détachées pour équipement standard de sécurité - Ersatzteile für Sicherheitsgrundausrüstung - Recambios para equipamiento básico de seguridad

A+B+C = Ricambi per dotazione estesa di sicurezza - Spare parts for extended safety fittings - Pièces détachées pour équipement complet de sécurité - Ersatzteile für erweiterte Sicherheitsausstattung - Recambios para equipamiento general de seguridad

RIELLO

RIELLO S.p.A.
I-37045 Legnago (VR)
Tel.: +39.0442.630111
[http:// www.riello.it](http://www.riello.it)
[http:// www.riello.com](http://www.riello.com)