

GB **Forced draught gas burners**

Progressive two-stage operation



| CODE | MODEL | TYP |
|----------|--------|--------|
| 20194286 | RS 70 | 821 T1 |
| 20194878 | RS 70 | 821 T1 |
| 20194881 | RS 100 | 822 T1 |
| 20194884 | RS 100 | 822 T1 |
| 20194885 | RS 130 | 823 T1 |
| 20194887 | RS 130 | 823 T1 |



Translation of the original instructions

| | | |
|----------|--|-----------|
| 1 | Declarations | 3 |
| 2 | Information and general warnings | 4 |
| 2.1 | Information about the instruction manual | 4 |
| 2.1.1 | Introduction..... | 4 |
| 2.1.2 | General dangers..... | 4 |
| 2.1.3 | Other symbols | 4 |
| 2.1.4 | Delivery of the system and the instruction manual..... | 5 |
| 2.2 | Guarantee and responsibility..... | 5 |
| 3 | Safety and prevention | 6 |
| 3.1 | Background | 6 |
| 3.2 | Personnel training | 6 |
| 4 | Technical description of the burner | 7 |
| 4.1 | Burner designation | 7 |
| 4.2 | Models available..... | 7 |
| 4.3 | Burner categories - Countries of destination | 8 |
| 4.4 | Technical data | 8 |
| 4.5 | Electrical data..... | 8 |
| 4.6 | Maximum dimensions..... | 9 |
| 4.7 | Burner equipment..... | 9 |
| 4.8 | Firing rates | 10 |
| 4.9 | Test boiler..... | 11 |
| 4.9.1 | Commercial boilers..... | 11 |
| 4.10 | Burner description | 12 |
| 4.11 | Electrical panel description..... | 13 |
| 4.12 | Control box RMG88..... | 14 |
| 4.13 | Servomotor (SQN73.4B4A20)..... | 15 |
| 5 | Installation | 16 |
| 5.1 | Notes on safety for the installation | 16 |
| 5.2 | Handling | 16 |
| 5.3 | Preliminary checks | 16 |
| 5.4 | Operating position | 17 |
| 5.5 | Preparing the boiler | 17 |
| 5.5.1 | Boring the boiler plate | 17 |
| 5.5.2 | Blast tube length..... | 17 |
| 5.5.3 | Securing the burner to the boiler | 17 |
| 5.6 | Access to head internal part..... | 18 |
| 5.6.1 | Combustion head pre-calibration | 18 |
| 5.7 | Positioning the probe - electrode..... | 18 |
| 5.8 | Combustion head adjustment..... | 19 |
| 5.9 | Gas feeding | 20 |
| 5.9.1 | Gas feeding line | 20 |
| 5.9.2 | Gas train..... | 21 |
| 5.9.3 | Gas train installation..... | 21 |
| 5.9.4 | Gas pressure | 21 |
| 5.10 | Electrical wiring | 23 |
| 5.10.1 | Supply cables and external connections passage | 23 |
| 5.11 | Calibration of the thermal relay | 24 |
| 5.12 | Measuring the ionisation current | 24 |
| 6 | Start-up, calibration and operation of the burner | 25 |
| 6.1 | Notes on safety for the first start-up | 25 |
| 6.2 | Adjustments prior to ignition | 25 |

| | | |
|----------|--|-----------|
| 6.3 | Burner start-up | 25 |
| 6.4 | Servomotor adjustment..... | 26 |
| 6.5 | Burner ignition..... | 27 |
| 6.6 | Adjusting the burner | 27 |
| 6.6.1 | Ignition output | 27 |
| 6.6.2 | Output in 2nd stage..... | 27 |
| 6.6.3 | Output in 1st stage..... | 28 |
| 6.7 | Pressure switch adjustment | 29 |
| 6.7.1 | Air pressure switch..... | 29 |
| 6.7.2 | Minimum gas pressure switch..... | 29 |
| 6.8 | Operation sequence of the burner | 30 |
| 6.8.1 | Burner start-up | 30 |
| 6.8.2 | Operation | 30 |
| 6.8.3 | Ignition failure..... | 30 |
| 6.8.4 | Burner flame goes out during operation..... | 30 |
| 6.9 | Stopping of the burner | 31 |
| 6.10 | Final checks (with burner operating)..... | 31 |
| 7 | Maintenance | 32 |
| 7.1 | Notes on safety for the maintenance | 32 |
| 7.2 | Maintenance programme | 32 |
| 7.2.1 | Maintenance frequency..... | 32 |
| 7.2.2 | Safety test - with gas feeding closed | 32 |
| 7.2.3 | Checking and cleaning..... | 32 |
| 7.2.4 | Combustion control (gas)..... | 33 |
| 7.2.5 | Safety components | 33 |
| 7.2.6 | Checking the air and gas pressure on the combustion head | 33 |
| 7.3 | Opening the burner | 34 |
| 7.4 | Closing the burner..... | 34 |
| 8 | Faults - Possible causes - Solutions..... | 35 |
| A | Appendix - Accessories | 37 |
| B | Appendix - Electrical panel layout..... | 38 |

1 Declarations

Declaration of conformity in accordance with ISO / IEC 17050-1

| | | | |
|---|--|-------------------------------|--|
| Manufacturer: | RIELLO S.p.A. | | |
| Address: | Via Pilade Riello, 7 37045 Legnago (VR) | | |
| Product: | Forced draught gas burners | | |
| Model and type: | RS 70 | 821 T1 | |
| | RS 100 | 822 T1 | |
| | RS 130 | 823 T1 | |
| These products are in compliance with the following Technical Standards: | | | |
| EN 676 | | | |
| EN 12100 | | | |
| and according to the European Directives: | | | |
| GAR | 2016/426/EU | Gas Appliances Regulation | |
| MD | 2006/42/EC | Machine Directive | |
| LVD | 2014/35/UE | Low Voltage Directive | |
| EMC | 2014/30/UE | Electromagnetic Compatibility | |
| Such products are marked as follows: | | | |
|  | EC -0085AP0944 | | |
| | EC -0085AP0945 | | |
| | EC -0085AP0946 | | |

Quality is ensured by means of a quality and management system that is ISO 9001:2015 certified.

Legnago, 03.05.2021

Research and Development Director
RIELLO S.p.A. - Burners Department

Eng. F. Maltempi



2 Information and general warnings

2.1 Information about the instruction manual

2.1.1 Introduction

The instruction manual supplied with the burner:

- is an integral and essential part of the product and must not be separated from it; it must therefore be kept carefully for any necessary consultation and must accompany the burner even if it is transferred to another owner or user, or to another system. If the manual is lost or damaged, another copy must be requested from the Technical Assistance Centre of the area;
- is designed for use by qualified personnel;
- offers important indications and instructions relating to the installation safety, start-up, use and maintenance of the burner.

Symbols used in the manual

In some parts of the manual you will see triangular DANGER signs. Pay great attention to these, as they indicate a situation of potential danger.

2.1.2 General dangers

The **dangers** can be of **3 levels**, as indicated below.



Maximum danger level!
This symbol indicates operations which, if not carried out correctly, cause serious injury, death or long-term health risks.



This symbol indicates operations which, if not carried out correctly, may cause serious injury, death or long-term health risks.



This symbol indicates operations which, if not carried out correctly, may cause damage to the machine and/or injury to people.

2.1.3 Other symbols



DANGER: LIVE COMPONENTS
This symbol indicates operations which, if not carried out correctly, lead to electric shocks with lethal consequences.



DANGER: FLAMMABLE MATERIAL
This symbol indicates the presence of flammable materials.



DANGER: BURNING
This symbol indicates the risks of burns due to high temperatures.



DANGER: CRUSHING OF LIMBS
This symbol indicates the presence of moving parts: danger of crushing of limbs.



WARNING: MOVING PARTS
This symbol indicates that you must keep limbs away from moving mechanical parts; danger of crushing.



DANGER: EXPLOSION
This symbol signals places where an explosive atmosphere may be present. An explosive atmosphere is defined as a mixture - under atmospheric conditions - of air and flammable substances in the form of gases, vapours, mist or dust in which, after ignition has occurred, combustion spreads to the entire unburned mixture.



PERSONAL PROTECTION EQUIPMENT
These symbols indicate the equipment that must be worn and kept by the operator for protection against threats against safety and/or health while at work.



OBLIGATION TO ASSEMBLE THE COVER AND ALL THE SAFETY AND PROTECTION DEVICES
This symbol signals the obligation to reassemble the cover and all the safety and protection devices of the burner after any maintenance, cleaning or checking operations.



ENVIRONMENTAL PROTECTION
This symbol gives indications for the use of the machine with respect for the environment.



IMPORTANT INFORMATION
This symbol indicates important information that you must bear in mind.

- This symbol indicates a list.

Abbreviations used

| | |
|------|---------|
| Ch. | Chapter |
| Fig. | Figure |
| Page | Page |
| Sec. | Section |
| Tab. | Table |

2.1.4 Delivery of the system and the instruction manual

When the system is delivered, it is important that:

- the instruction manual is delivered to the user by the system manufacturer, with the recommendation to keep it in the room where the heat generator is to be installed.
- The instruction manual shows:
 - the serial number of the burner;

.....

- the address and telephone number of the nearest Assistance Centre.

.....

- The system supplier must carefully inform the user about:
 - the use of the system;
 - any further tests that may be required before activating the system;
 - maintenance, and the need to have the system checked at least once a year by a representative of the manufacturer or another specialised technician.
 To ensure a periodic check, the manufacturer recommends the drawing up of a Maintenance Contract.

2.2 Guarantee and responsibility

The manufacturer guarantees its new products from the date of installation, in accordance with the regulations in force and/or the sales contract. At the moment of the first start-up, check that the burner is integral and complete.



WARNING

Failure to observe the information given in this manual, operating negligence, incorrect installation and carrying out of non authorised modifications will result in the annulment by the manufacturer of the guarantee that it supplies with the burner.

In particular, the rights to the guarantee and the responsibility will no longer be valid, in the event of damage to things or injury to people, if such damage/injury was due to any of the following causes:

- incorrect installation, start-up, use and maintenance of the burner;
- improper, incorrect or unreasonable use of the burner;
- intervention of unqualified personnel;
- carrying out of unauthorised modifications on the appliance;
- use of the burner with safety devices that are faulty, incorrectly applied and/or not working;
- installation of untested supplementary components on the burner;
- powering of the burner with unsuitable fuels;
- faults in the fuel supply system;
- use of the burner even following an error and/or an irregularity;
- repairs and/or overhauls incorrectly carried out;
- modification of the combustion chamber with inserts that prevent the regular development of the structurally established flame;
- insufficient and inappropriate surveillance and care of those burner components most likely to be subject to wear and tear;
- use of non-original components, including spare parts, kits, accessories and optionals;
- force majeure.

The manufacturer furthermore declines any and every responsibility for the failure to observe the contents of this manual.

3 Safety and prevention

3.1 Background

The burners have been designed and built in compliance with current regulations and directives, applying the known technical rules of safety and envisaging all the potential danger situations.

It is necessary, however, to bear in mind that the imprudent and clumsy use of the equipment may lead to situations of death risk for the user or third parties, as well as the damaging of the burner or other items. Inattention, thoughtlessness and excessive confidence often cause accidents; the same applies to tiredness and sleepiness.

It is a good idea to remember the following:

- The burner must only be used as expressly described. Any other use should be considered improper and therefore dangerous.

Namely:

it can be applied to boilers operating with water, steam, diathermic oil, and to other uses expressly named by the manufacturer; the type and pressure of the fuel, the voltage and frequency of the electrical power supply, the minimum and maximum deliveries for

which the burner has been regulated, the pressurisation of the combustion chamber, the dimensions of the combustion chamber and the ambient temperature must all be within the values indicated in the instruction manual.

- Modification of the burner to alter its performance and destinations is not allowed.
- The burner must be used in exemplary technical safety conditions. Any disturbances that could compromise safety must be quickly eliminated.
- Opening or tampering with the burner components is not allowed, apart from the parts requiring maintenance.
- Only those parts envisaged by the manufacturer can be replaced.



The manufacturer guarantees safety and proper functioning only if all burner components are intact and positioned correctly.

3.2 Personnel training

The user is the person, body or company that has acquired the machine and intends to use it for the specific purpose. He is responsible for the machine and for the training of the people working around it.

The user:

- undertakes to entrust the machine exclusively to suitably trained and qualified personnel;
- undertakes to inform his personnel in a suitable way about the application and observance of the safety instructions. With that aim, the user undertakes to ensure that everyone knows the use and safety instructions for his own duties.
- Personnel must follow all the danger and caution indications shown on the machine.
- Personnel must not carry out, on their own initiative, operations or interventions that are not within their province.
- Personnel are obliged to inform their superiors of every problem or dangerous situation that may arise.
- The assembly of parts of other makes, or any modifications, can alter the characteristics of the machine and hence compromise operating safety. The manufacturing company therefore accepts no responsibility whatsoever for any which may result from the use of non-original parts.

In addition:



- the user must take all the measures necessary to prevent unauthorised people gaining access to the machine;
- the user must inform the manufacturer if faults or malfunctioning of the accident prevention systems are noticed, along with any presumed danger situation;
- personnel must always use the personal protective equipment envisaged by legislation and follow the indications given in this manual.

4 Technical description of the burner

4.1 Burner designation

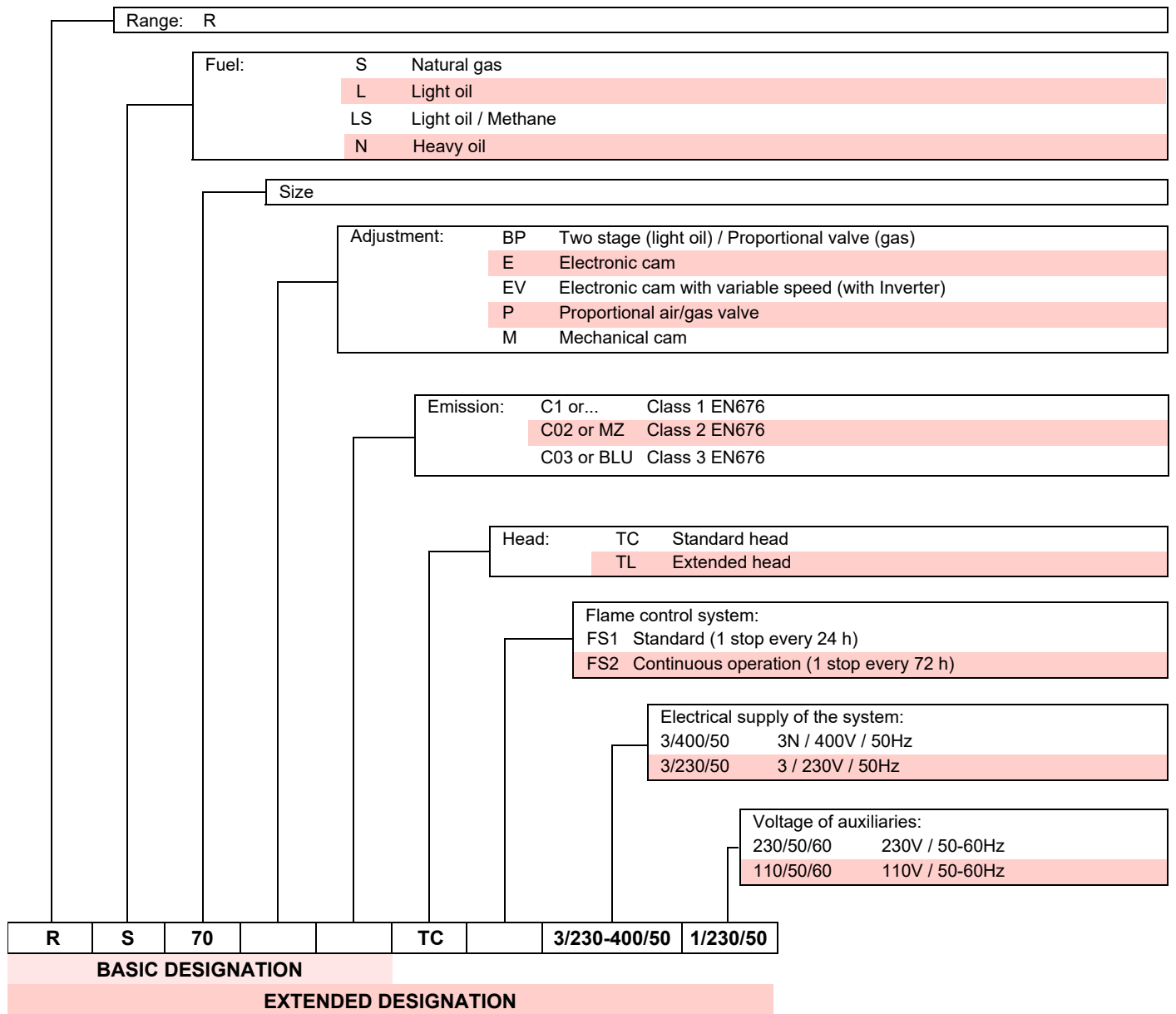

4.2 Models available

| Designation | | Voltage | Start-up | Code |
|-------------|----|--------------|----------|----------|
| RS 70 | TC | 3/230-400/50 | Direct | 20194286 |
| RS 70 | TL | 3/230-400/50 | Direct | 20194878 |
| RS 100 | TC | 3/230-400/50 | Direct | 20194881 |
| RS 100 | TL | 3/230-400/50 | Direct | 20194884 |
| RS 130 | TC | 3/230-400/50 | Direct | 20194885 |
| RS 130 | TL | 3/230-400/50 | Direct | 20194887 |

4.3 Burner categories - Countries of destination

| Country of destination | Gas category |
|--|--------------|
| AT, BG, CH, CZ, DK, EE, FI, GR, HU, IS, IT, LT, NO, RO, SE, SK, SI, TR | II2H3B/P |
| ES, GB, IE, PT | II2H3P |
| LU, PL | II2E3B/P |
| BE | I2E(R) I3P |
| DE | II2ELL3B/P |
| CY, MT | I3B/P |
| NL | II2EK3B/P |
| FR | II2Er3P |
| LV | I2H |

4.4 Technical data

| Model | | | RS 70 | | RS 100 | | RS 130 | |
|------------------------------------|----------------|----------------------|--|------|------------|------|------------|------|
| Type | | | 821 T1 | | 822 T1 | | 823 T1 | |
| Power (1) | 2nd stage | kW | 465 - 814 | | 698 - 1163 | | 930 - 1512 | |
| | | Mcal/h | 400 - 700 | | 600 - 1000 | | 800 - 1300 | |
| | min. 1st stage | kW | 192 | | 232 | | 372 | |
| | | Mcal/h | 165 | | 200 | | 320 | |
| Fuel | | | NATURAL GAS: G20 - G25 | | | | | |
| | | | G20 | G25 | G20 | G25 | G20 | G25 |
| - net calorific value | | kWh/Nm ³ | 10 | 8.6 | 10 | 8.6 | 10 | 8.6 |
| | | Mcal/Nm ³ | 8.6 | 7.4 | 8.6 | 7.4 | 8.6 | 7.4 |
| - absolute density | | kg/Nm ³ | 0.71 | 0.78 | 0.71 | 0.78 | 0.71 | 0.78 |
| - max delivery | | Nm ³ /h | 81 | 94 | 116 | 135 | 151 | 175 |
| - pressure at maximum delivery (2) | | mbar | 30.2 | 44.5 | 11.6 | 16.4 | 11.7 | 17.2 |
| Operation | | | <ul style="list-style-type: none"> On-Off (1 stop min each 24 hours). Two-stage (high and low flame) and one-stage (all - nothing) | | | | | |
| Standard applications | | | Boilers: water, steam, diathermic oil | | | | | |
| Ambient Temperature | | °C | 0 - 40 | | | | | |
| Combustion air temperature | | °C max | 60 | | | | | |
| Noise levels (3) | Sound Pressure | dB(A) | 75 | | 77 | | 78.5 | |
| | Sound Output | | 85 | | 88 | | 89.5 | |

Tab. A

- (1) Reference conditions: Ambient temperature 20°C - Gas temperature 15°C - Barometric pressure 1,013 mbar - Altitude 0 m a.s.l.
 (2) Pressure at test point 16)Fig. 4 on page 12) with zero pressure in combustion chamber and at maximum burner output.
 (3) Sound pressure measured in manufacturer's combustion laboratory, with burner operating on test boiler and at maximum rated output. The sound power is measured with the "Free Field" method, as per EN 15036, and according to an accurate "Accuracy: Category 3" measurement, as described in EN ISO 3746.
 (4) Blast tube: short-long

4.5 Electrical data

| Model | | RS 70 | | RS 100 | | RS 130 | | |
|-------------------------------------|-----|----------------------------|------------------|-----------|------|---------|------|--|
| Main electrical supply | | 3 ~ 230 - 400V +/-10% 50Hz | | | | | | |
| Auxiliary circuit electrical supply | | 1N ~ 230 V 50 Hz | | | | | | |
| Fan motor IE3 | rpm | 2880 | | 2890 | | 2890 | | |
| | V | 220-240 | | 220-240 | | 220-240 | | |
| | | 380-415 | | 380-415 | | 380-415 | | |
| | W | 1100 | | 1500 | | 2200 | | |
| | A | 4.3 - 2.5 | | 5.9 - 3.4 | | 8 - 4.6 | | |
| Ignition transformer | | V1 - V2 | 230 V - 1 x 8 kV | | | | | |
| | | I1 - I2 | 1 A - 20 mA | | | | | |
| Absorbed electric power | | W max | 1400 | | 1800 | | 2600 | |
| Protection level | | IP 44 | | | | | | |

Tab. B

4.6 Maximum dimensions

The maximum dimensions of the burner are given in Fig. 1.

Note that to inspect the combustion head the burner must be moved backward and turned upward. The maximum dimension of the open burner, without cover, is given by measurement U.

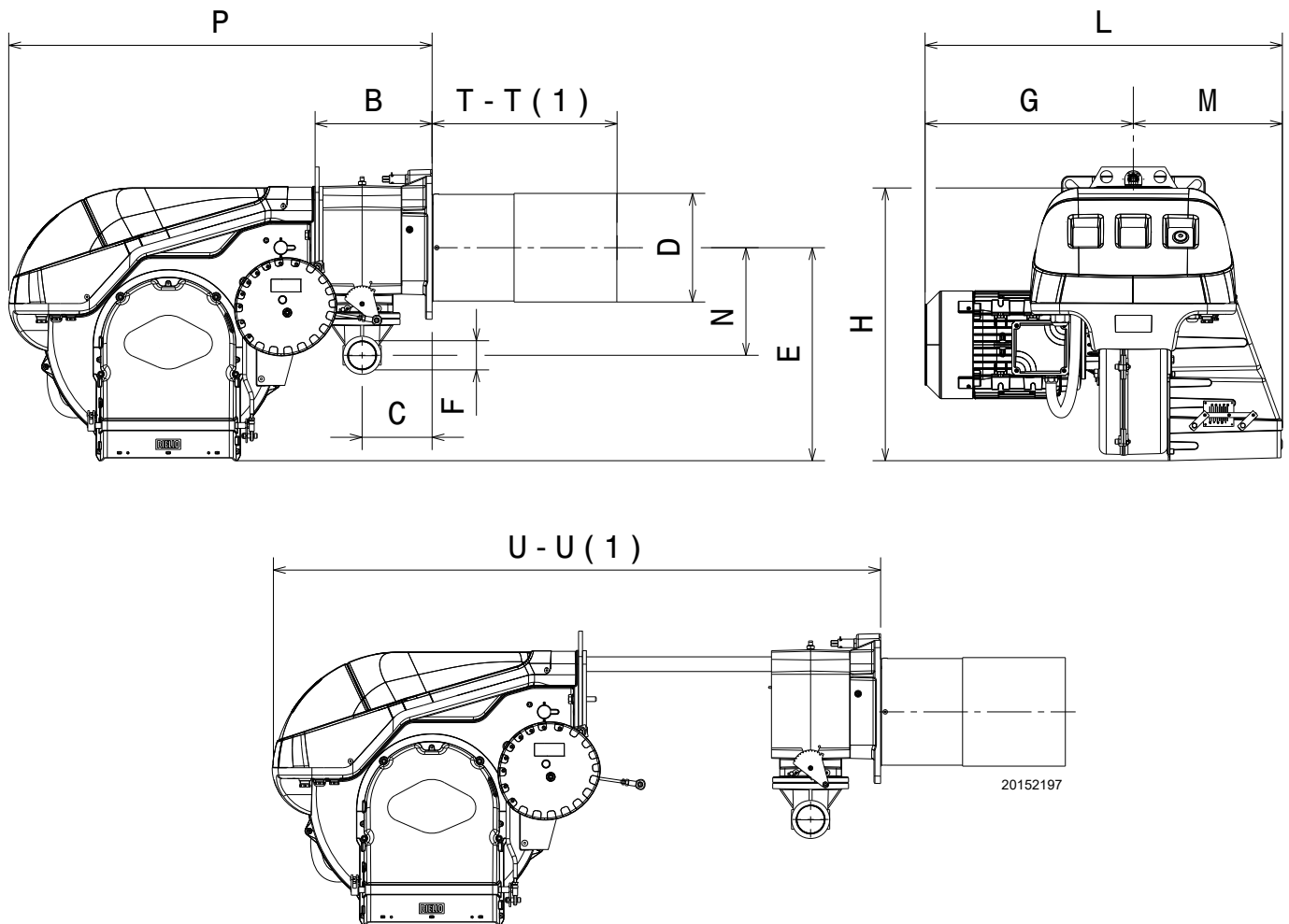

Fig. 1

| mm | B | C | D | E | F | G | H | L | M | N | P | T-T ₍₁₎ | U-U ₍₁₎ |
|--------|-----|-----|-----|-----|----|-----|-----|-----|-----|-----|-----|--------------------|--------------------|
| RS 70 | 212 | 131 | 179 | 425 | 2" | 295 | 550 | 511 | 216 | 220 | 837 | 250-385 | 1221-1356 |
| RS 100 | 212 | 131 | 179 | 425 | 2" | 312 | 550 | 528 | 216 | 220 | 837 | 250-385 | 1221-1356 |
| RS 130 | 212 | 131 | 189 | 425 | 2" | 337 | 550 | 553 | 216 | 220 | 837 | 280-415 | 1221-1356 |

Tab. C

⁽¹⁾ Blast tube: short-long

4.7 Burner equipment

- Flange for gas trainNo. 1
- Gasket for flangeNo. 1
- Flange fixing screws M10 x 35No. 4
- Thermal insulation screenNo. 1
- Screws to fix the burner flange to the boiler M12 x 35No. 4
- Plugs assembly.No. 1
- Instruction bookletNo. 1
- Spare parts listNo. 1

4.8 Firing rates

The RS 70 - 100 - 130 burners can operate in two modes: one-stage or two-stage.

The **MAXIMUM OUTPUT** is selected from within area A (and B for RS 130)(Fig. 2). To use also area B (RS 130) the combustion head needs to be re-calibrated. See "Combustion head pre-calibration" on page 18.

The **MINIMUM OUTPUT** must not be lower than the minimum limit of the diagram:

- RS 70 = 192 kW
- RS 100 = 232 kW
- RS 130 = 372 kW



The firing rate value (Fig. 2) has been obtained considering an ambient temperature of 20 °C, an atmospheric pressure of 1,013 mbar (approx. 0 m a.s.l.), and with the combustion head adjusted as shown on page 19.

D950

RS 70

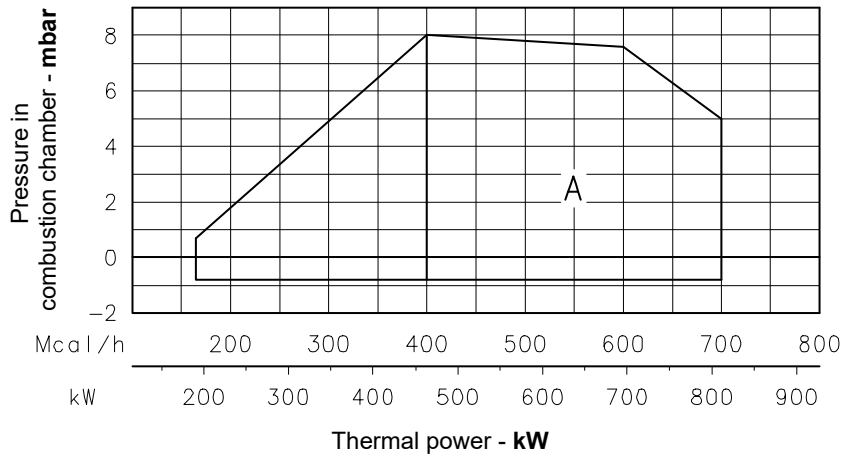

RS 100

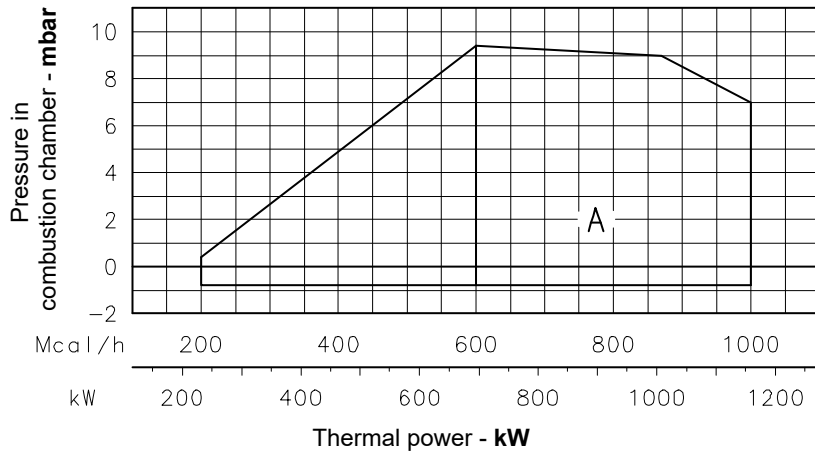

RS 130

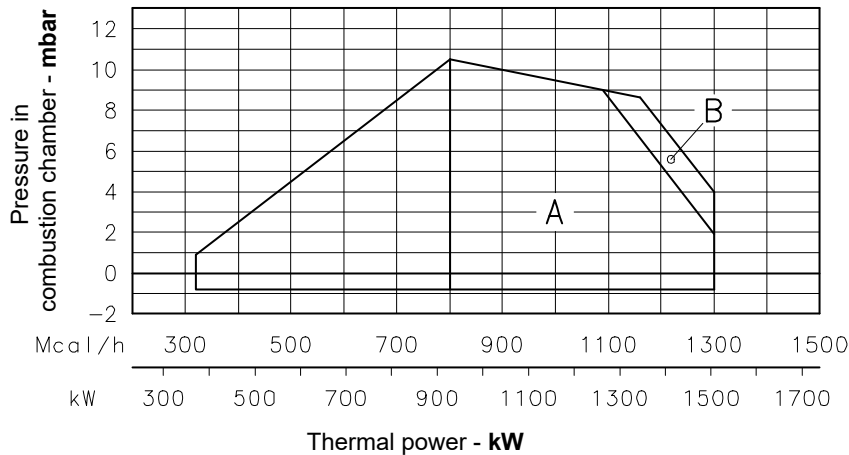

Fig. 2

4.9 Test boiler

The burner/boiler combination does not pose any problems if the boiler is EC approved and its combustion chamber dimensions are similar to those indicated in the diagram (Fig. 3).

If the burner must be combined with a boiler that has not been EC approved and/or its combustion chamber dimensions are clearly smaller than those indicated in the diagram, consult the manufacturer.

The firing rates were set in relation to special test boilers, according to EN 676 regulations.

In Fig. 3 you can see the diameter and length of the test combustion chamber.

Example:

Output 756 kW: diameter = 60 cm; length = 2 m.

4.9.1 Commercial boilers

The burner/boiler combination does not pose any problems if the boiler is EC approved and its combustion chamber dimensions are similar to those indicated in the diagram (Fig. 3).

If the burner must be used with a commercial boiler that has not been EC approved and/or its combustion chamber dimensions are clearly smaller than those indicated in the diagram (Fig. 3), consult the manufacturer.

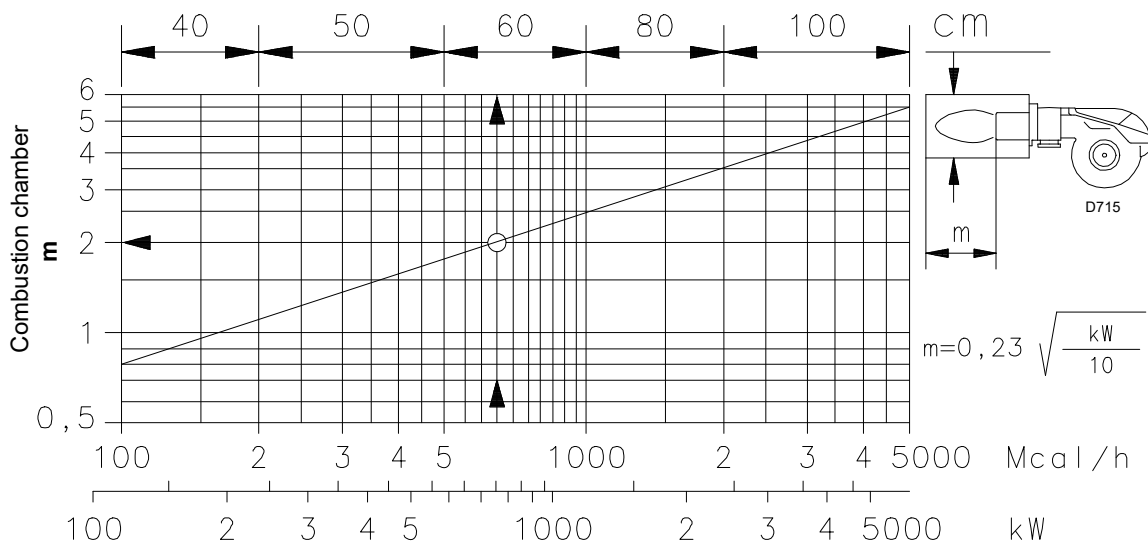

Fig. 3

4.10 Burner description

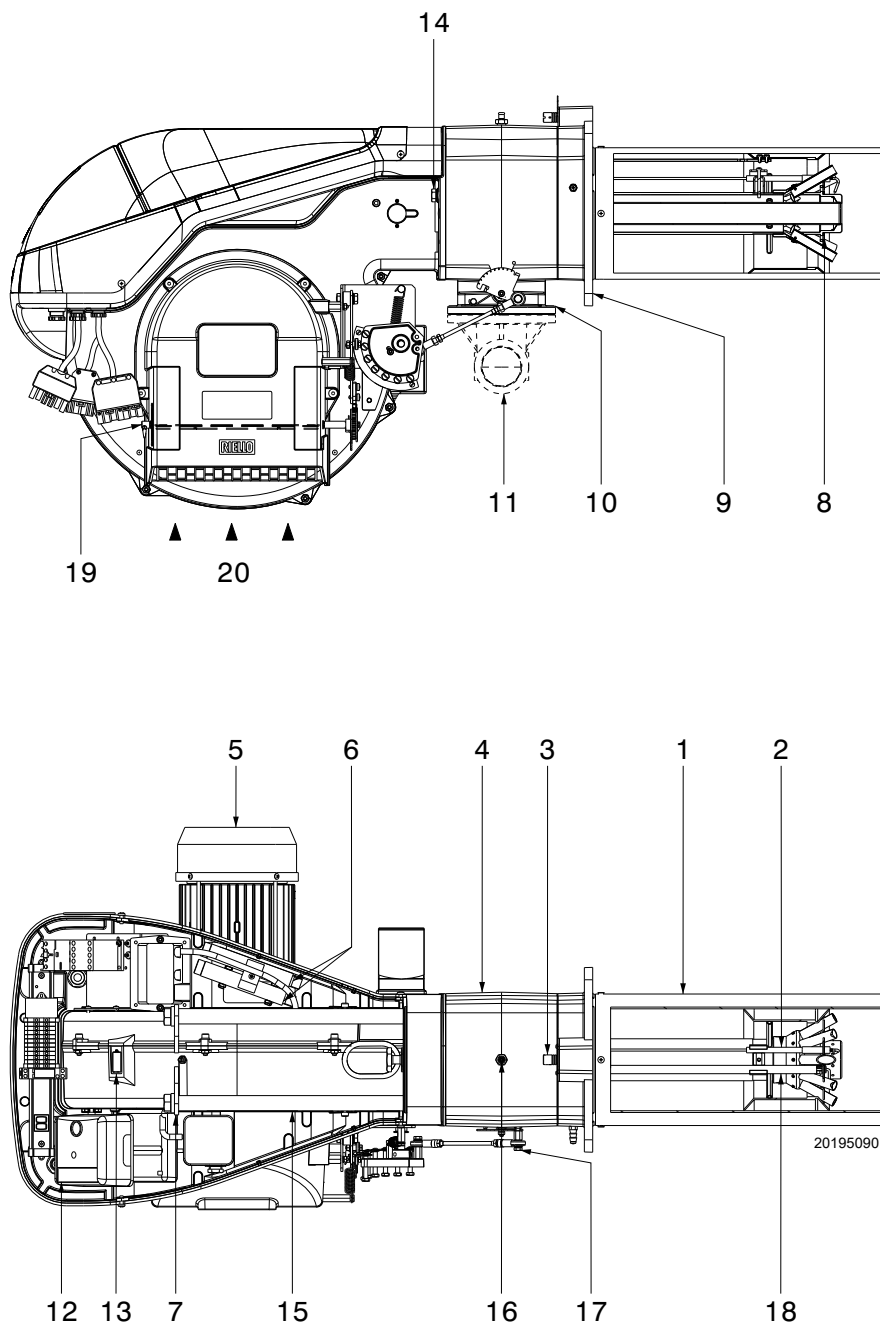

Fig. 4

- 1 Combustion head
- 2 Ignition electrode
- 3 Screw for combustion head adjustment
- 4 Pipe coupling
- 5 Fan motor
- 6 Extensions for slide bars
- 7 Lifting rings
- 8 Flame stability disc
- 9 Boiler fixing flange
- 10 Gas butterfly valve
- 11 Gas input pipe
- 12 Control box with lockout pilot light and lockout reset button
- 13 Flame inspection window
- 14 Screw securing fan to pipe coupling
- 15 Slide bars for opening the burner and inspecting the combustion head
- 16 Gas pressure test point and head fixing screw
- 17 Air pressure test point
- 18 Flame sensor probe

- 19 Air damper
- 20 Fan air inlet

Two types of burner failure may occur:

CONTROL BOX LOCKOUT:

if the control box button 12)(red led)(Fig. 4) lights up, it indicates that the burner is in lockout.

To reset, hold the button down for between 1 and 3 seconds.

MOTOR LOCKOUT:

to release press the button on the thermal relay.

4.11 Electrical panel description

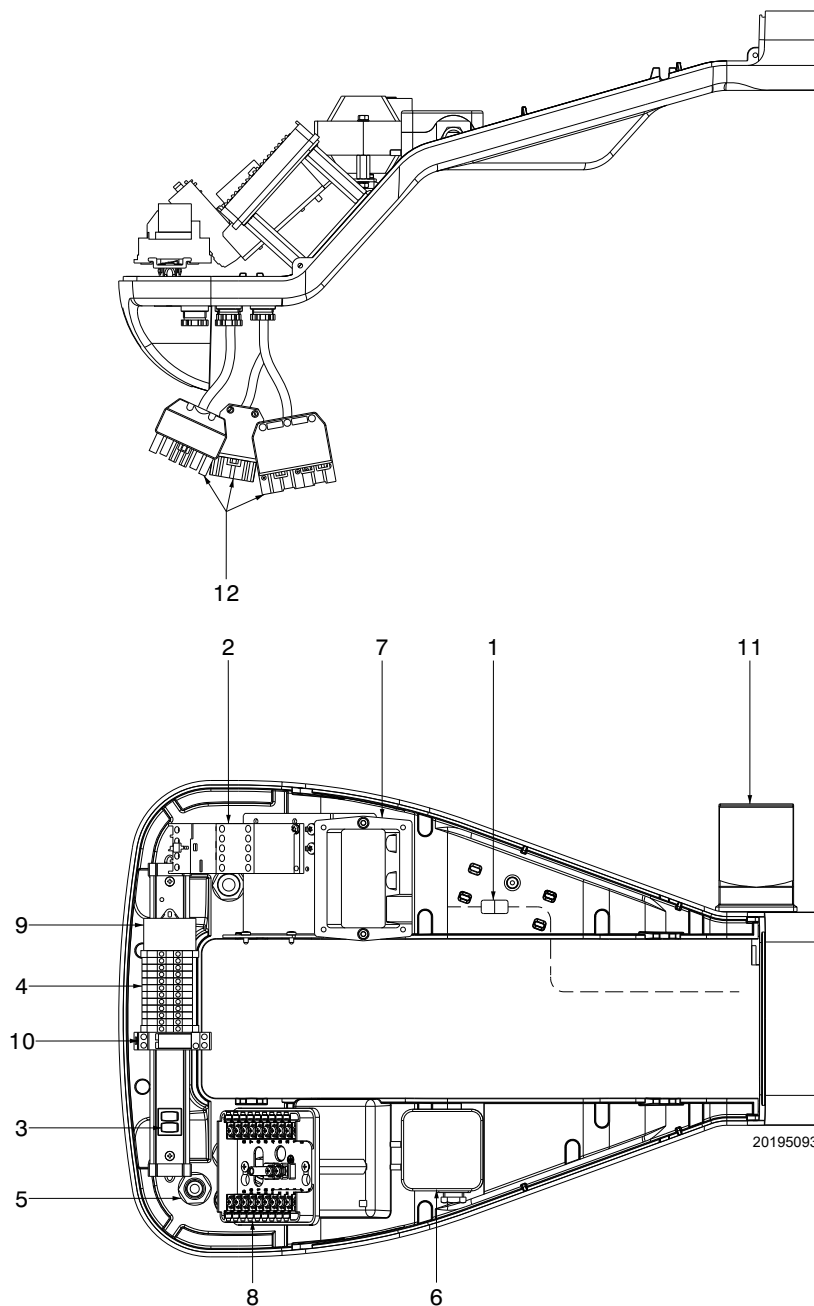

Fig. 5

- 1 Plug-socket on ionisation probe cable
- 2 Motor contactor and thermal relay with reset button
- 3 Two switches:
 - one for "on - off burner"
 - one for "1st - 2nd stage"
- 4 Terminal board for electric connection
- 5 Cable grommets for electrical wiring (to be carried out by the installer)
- 6 Air pressure switch (differential type)
- 7 Ignition transformer
- 8 Control box base
- 9 Filter to protect against radio disturbance
- 10 Relay
- 11 Servomotor
- 12 Socket for electrical connection

4.12 Control box RMG88...

Important notes



To avoid accidents, material or environmental damage, observe the following instructions!

The control box RMG88... is a safety device! Avoid opening or modifying it, or forcing its operation. Riello S.p.A. cannot assume any responsibility for damage resulting from unauthorised interventions!

- All interventions (assembly and installation operations, assistance, etc.) must be carried out by qualified personnel.
- Before modifying the wiring in the control box connection area, fully disconnect the system from the power supply (omnipolar separation). Check the system is not powered and cannot be accidentally reconnected. Failure to do this will lead to the risk of electrocution.
- Protection against electrocution from the control box and all connected electric components is obtained with the correct assembly.
- Before any intervention (assembly and installation operations, assistance, etc.), ensure the wiring is in order and that the parameters are correctly set, then make the safety checks.
- Falls and collisions can negatively affect the safety functions.
In this case, the control box must not be operated, even if it displays no evident damage.
- Press the reset button of the burner lockout command or the reset button (by applying a force of not more than 10 N), without the aid of tools or sharp objects.

For the safety and reliability of the control box, comply with the following instructions:

- avoid conditions that can favour the development of condensate and humidity. Otherwise, before switching on again, make sure that the entire control box is perfectly dry!
- Static charges must be avoided since they can damage the control box's electronic components when touched.



Fig. 6

Technical data

| | |
|---------------------------|------------------------------|
| Mains voltage | AC 220...240 V +10 % / -15 % |
| Mains frequency | 50 / 60 Hz ±6% |
| Power absorption | 20 VA |
| Protection level | IP20 |
| Safety class | I |
| Weight | approx. 260g |
| Cable length | |
| Thermostat cable | Max. 20 m at 100 pF/m |
| Air pressure switch | Max. 1 m at 100 pF/m |
| Gas pressure switch | Max. 20 m at 100 pF/m |
| Remote reset | Max. 20 m at 100 pF/m |
| CPI | Max. 1 m at 100 pF/m |
| Environmental conditions: | |
| Operation | DIN EN 60721-3-3 |
| Climatic conditions | Class 3K3 |
| Mechanical conditions | Class 3M3 |
| Temperature range | -20...+60°C |
| Humidity | < 95 % r.h. |

Mechanical structure

The control box is made of plastic to resist knocks, heat and flame propagation.

The control box contains the following components:

- a microprocessor that controls the program sequence, and a relay for controlling the load;
- an electronic flame signal amplifier;
- a built-in reset button with 3 signalling colours (LED) for status and error messages.

4.13 Servomotor (SQN73.4B4A20)

Warnings



To avoid accidents, material or environmental damage, observe the following instructions!

Avoid opening, modifying or forcing the actuators.

- All interventions (assembly and installation operations, assistance, etc.) must be carried out by qualified personnel.
- Before modifying the wiring in the connection area of the servomotor, fully disconnect the burner control device from the power supply (omnipolar separation).
- To avoid the risk of electrocution, protect the connection terminals in a suitable manner and correctly fix the cover.
- Check the wiring is in order.
- Falls and collisions can negatively affect the safety functions. In this case, the servomotor must not be operated, even if it displays no evident damage.



The servomotor contains electric and electronic components that must not be disposed of with normal domestic waste.

Respect all current local legislation.

Assembly notes

- Check the relevant national safety standards are respected.
- When assembling the servomotor and connecting the damper, the gears can be disengaged by means of a lever, allowing the drive shaft to be easily adjusted in both directions of rotation.



20194236

Fig. 7

Technical data

| | |
|--------------------------|---|
| Operating voltage | AC 230 V -15% / +10% |
| Mains frequency | 50/60 Hz ±6% |
| Energy consumption | 6 VA |
| Angular positioning | Max. 160°, extension of the scale 0-130 ° |
| Assembly position | Any |
| Protection level | IP 54, in accordance with DIN 40050 |
| Switching voltage | 24...250V AC |
| Type of motor | Synchronous |
| Environmental conditions | |
| Storage | |
| Climatic conditions | DIN EN 60721-3-1 |
| Mechanical conditions | Class 1K3 |
| Temperature range | Class 1M2 |
| Humidity | -20...+60°C < 95% RH |
| Connection of the cable | Two grafting seats for the connection terminals Type CUM / Stelvio manufacturer for connector: - type CUF 5-4 (grafting seat X1) - type CUF 5-5 (grafting seat X2) Recommended section for cable braided min. 0.5 mm ² and max. 1.5mm ² . |

Tab. D

5.4 Operating position



- The burner is designed to work only in positions 1, 2, 3 and 4 (Fig. 9).
- Installation 1 is preferable, as it is the only one that allows the maintenance operations as described in this manual.
- Installations 2, 3 and 4 permit operation but make maintenance and inspection of the combustion head more difficult.



- Any other position could compromise the correct operation of the appliance.
- Installation 5 is prohibited for safety reasons.

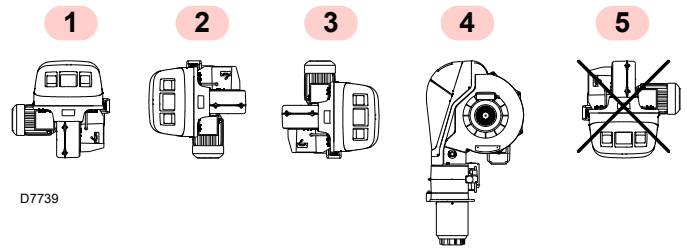

Fig. 9

5.5 Preparing the boiler

5.5.1 Boring the boiler plate

Pierce the closing plate of the combustion chamber, as in Fig. 10. The position of the threaded holes can be marked using the thermal insulation screen supplied with the burner.

| mm | A | B | C |
|--------|-----|---------|------|
| RS 70 | 185 | 275-325 | M 12 |
| RS 100 | 185 | 275-325 | M 12 |
| RS 130 | 195 | 275-325 | M 12 |

Tab. E

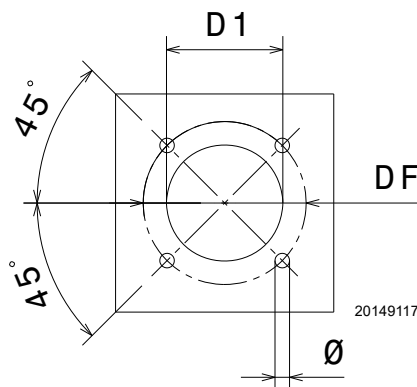

Fig. 10

5.5.2 Blast tube length

The length of the blast tube must be selected according to the indications provided by the manufacturer of the boiler, and in any case it must be greater than the thickness of the boiler door complete with its fettling.

The range of lengths available, L, is as follows:

| mm | RS 70 | RS 100 | RS 130 |
|-----------|-------|--------|--------|
| Standard | 250 | 250 | 280 |
| Allungato | 385 | 385 | 415 |

Tab. F

For boilers with front flue passes 15) or flame inversion chamber, a protection in refractory material 13) must be inserted between the boiler fettling 14) and the blast tube 12).

This protective fettling must not compromise the extraction of the blast tube.

For boilers with a water-cooled front piece, a refractory lining 13)-14)(Fig. 11) is not necessary, unless expressly requested by the boiler manufacturer.

5.5.3 Securing the burner to the boiler



Provide an adequate lifting system.

- Separate the combustion head from the rest of the burner (Fig. 11):
- loosen the 4 screws 3) and remove the hood 1)
- disengage the articulated coupling 7) from the graduated sector 8)
- remove the screws 2) from the two slide bars 5)
- remove the two screws 4) and pull the burner back on the slide bars 5) by about 100 mm.
- disconnect the electrode cables, then completely unthread the burner from the slide bars.

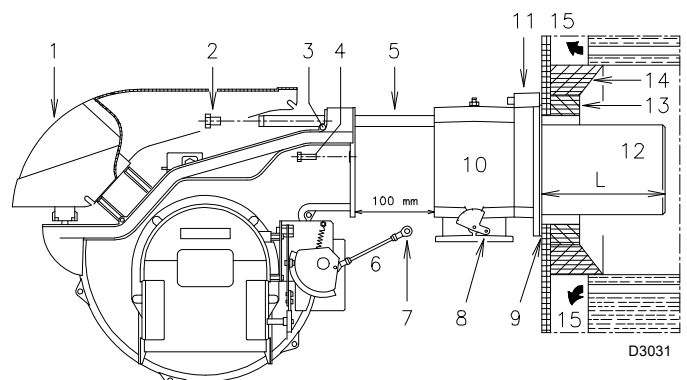

Fig. 11



The seal between burner and boiler must be airtight.

5.6 Access to head internal part

In order to reach inside the combustion head (Fig. 12) proceed as follows:

- remove the screw 1) and take out the internal part 2).

5.6.1 Combustion head pre-calibration

For the **RS 130** model, check, at this point, whether the maximum output of the burner in the 2nd stage is within area **A** or in area **B** of the firing rate.

See "Firing rates" on page 10.

- If it is in area A, no intervention is required.
- However, if it is in area B:
 - Unscrew the screws 1)(Fig. 13) and remove the blast tube 2).
 - Move the fixing point of the rod 3)(Fig. 13) from position A to position B, thereby moving the shutter 4) backwards.
 - Put back the blast tube 2)(Fig. 13) and the screws 1).

Once this operation has been carried out, fix the flange 9)(Fig. 11 on page 17 to the boiler plate, interposing the insulating gasket 7)(Fig. 11 on page 17 supplied.

Use the 4 screws, also supplied with the unit, after protecting the thread with anti-locking product.

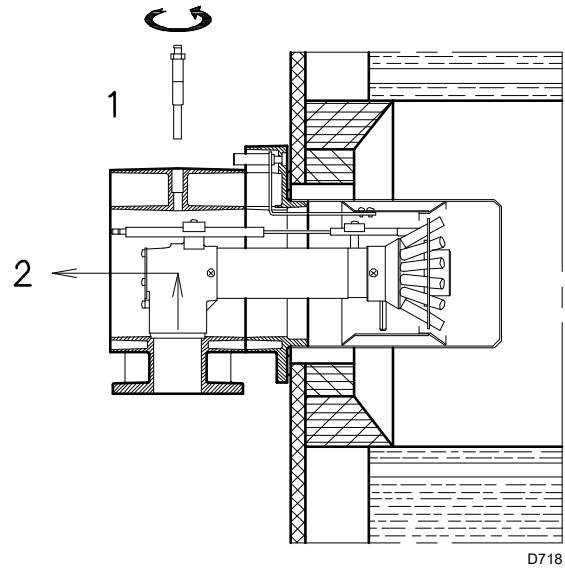

D718

Fig. 12

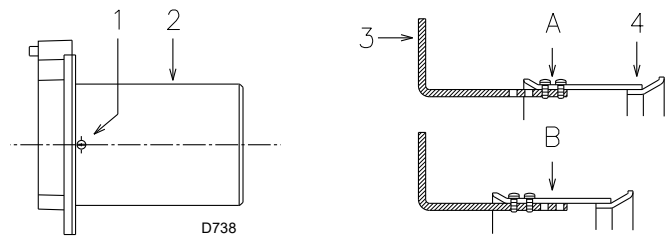

D738

Fig. 13

5.7 Positioning the probe - electrode



WARNING

Before securing the burner to the boiler, check (through the opening of the blast tube) that the probe and electrode are correctly positioned, as in Fig. 14.



WARNING

Do not rotate the probe: leave it as in Fig. 14 since if it is located too close to the ignition electrode, the control box amplifier may be damaged.

If the probe or electrode is not correctly positioned, you must:

- remove the screw 1)(Fig. 12);
- take out the inner part 2)(Fig. 12) of the head, and then calibrate them.



WARNING

Respect the dimensions shown in Fig. 14.

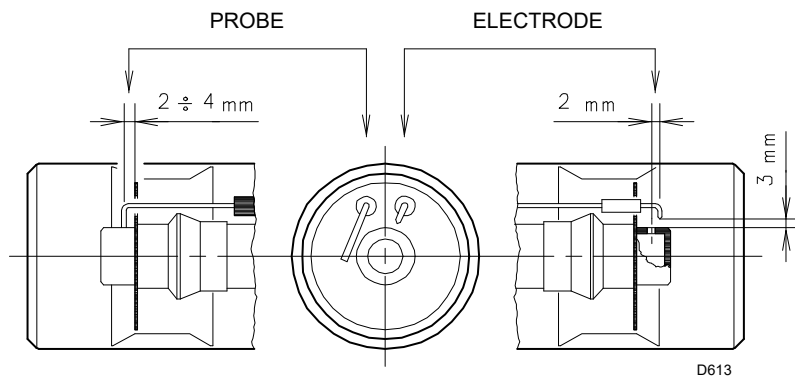

D613

Fig. 14

5.8 Combustion head adjustment

At this point of the installation, the combustion head is fixed to the boiler as shown in Fig. 12.

It is therefore especially easy to adjust, and this adjustment depends only on the maximum output of the burner.

The combustion head has 2 adjustments:

- air
- gas

In the diagram (Fig. 16) locate the notch to which both air and central gas/air should be adjusted.

Air adjustment

- Turn the screw 4)(Fig. 15) until the notch found lines up with the front surface 5) of the flange.



To facilitate the adjustment, loosen the screw 6)(Fig. 15), adjust, then block.

Gas adjustment

- Loosen the screws 1)(Fig. 15) and rotate the ring nut 2) until the notch you have found corresponds with the indicator 3).
- Block the 3 screws 4).

Example:

RS 70 burner output = 581 kW (500 Mcal/h).

The diagram (Fig. 16) shows that the gas and air adjustments for this output should be carried out on notch 3.

NOTE:

The diagram indicates the optimum adjustment for a type of boiler according to Fig. 3 on page 11.



The adjustments indicated can be modified during the initial start-up.

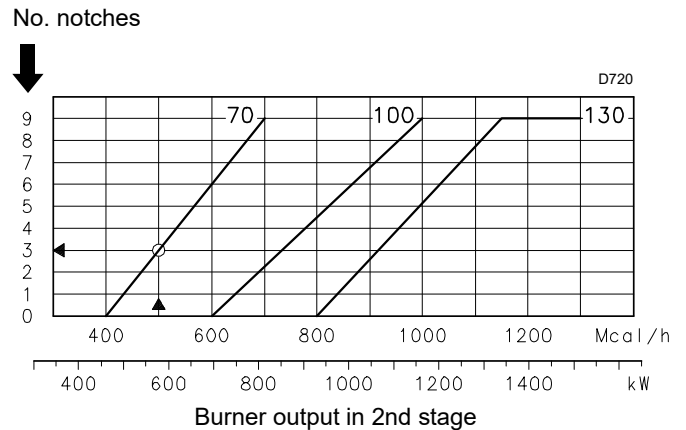

Fig. 16

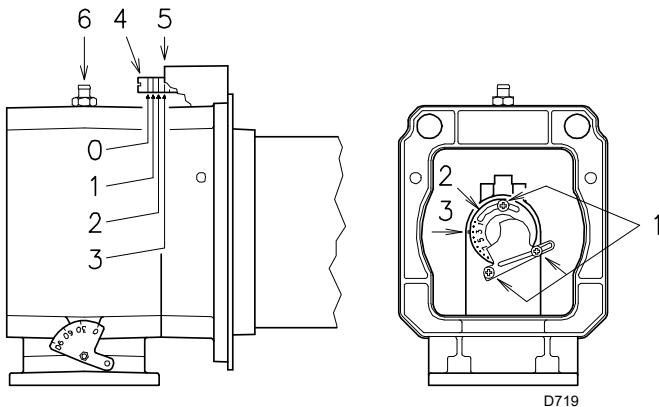

Fig. 15

5.9 Gas feeding



Explosion danger due to fuel leaks in the presence of a flammable source.

Precautions: avoid knocking, attrition, sparks and heat.

Make sure that the fuel interception tap is closed before performing any operation on the burner.



WARNING

The fuel supply line must be installed by qualified personnel, in compliance with current standards and laws.

5.9.1 Gas feeding line

Key (Fig. 17 - Fig. 18 - Fig. 19 - Fig. 20)

- 1 Gas input pipe
- 2 Manual valve
- 3 Vibration damping joint
- 4 Pressure gauge with push-button cock
- 5 Filter
- 6A Includes:
 - filter
 - working valve
 - safety valve
 - pressure adjuster
- 6B Includes:
 - working valve
 - safety valve
 - pressure adjuster
- 6C Includes:
 - safety valve
 - working valve
- 6D Includes:
 - safety valve
 - working valve
- 7 Minimum gas pressure switch
- 8 Leak detection control, provided as an accessory or integrated, based on the gas train code. In compliance with the EN 676 standard, the leak detection control is compulsory for burners with maximum outputs over 1200 kW.
- 9 Gasket, for "flanged" versions only
- 10 Pressure adjuster
- 11 Train-Burner adaptor, supplied separately
- P2 Upstream pressure of valves/adjuster
- P3 Upstream pressure of the filter
- L Gas train, supplied separately
- L1 The responsibility of the installer

MBC "threaded"

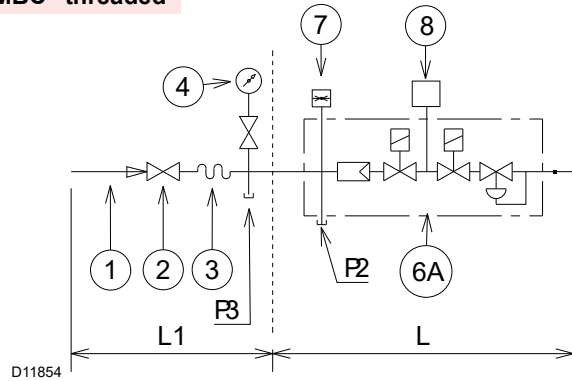

Fig. 17

MBC "flanged" - VGD

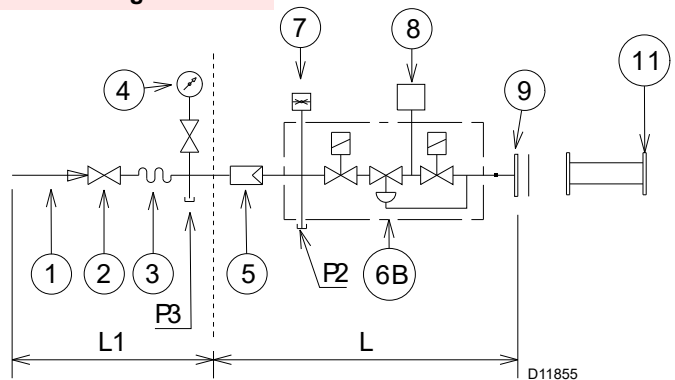

Fig. 18

DMV "flanged or threaded"

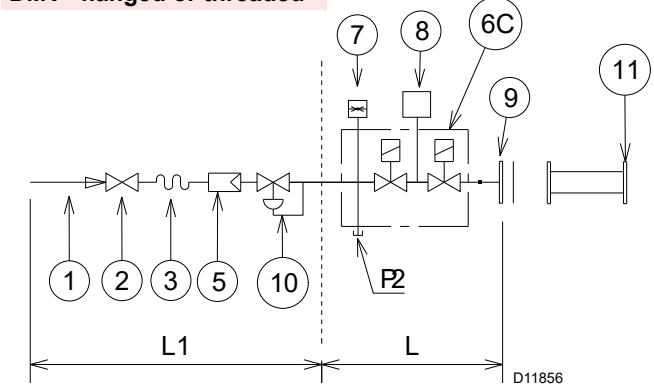

Fig. 19

CB "flanged or threaded"

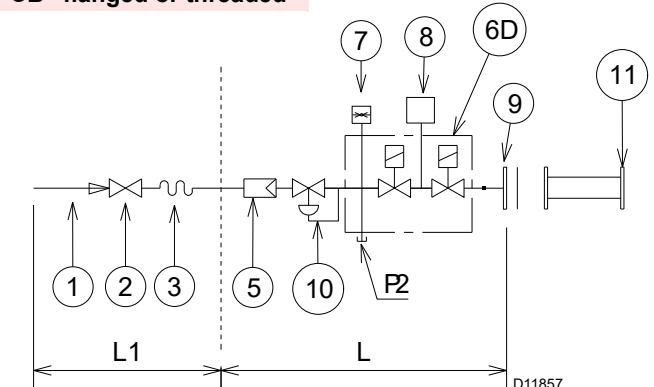

Fig. 20

5.9.2 Gas train

Approved according to standard EN 676 and provided separately from the burner.

5.9.3 Gas train installation



Disconnect the electrical power using the main switch.



Check that there are no gas leaks.



Pay attention when handling the train: danger of crushing of limbs.



Make sure that the gas train is properly installed by checking for any fuel leaks.



The operator must use the required equipment during installation.

The gas train must be connected to the gas connection 1)(Fig. 21), using the flange 2), the gasket 3) and the screws 4) supplied with the burner.

The train can enter the burner from the right or left side, depending on which is the most convenient, see Fig. 21.

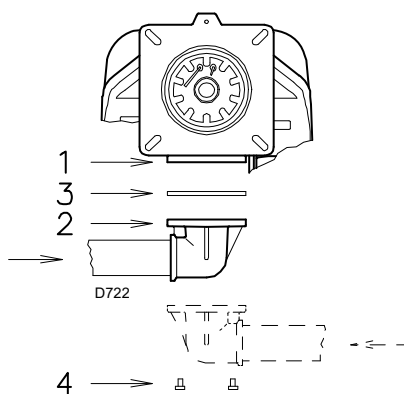

Fig. 21

5.9.4 Gas pressure

indicates the pressure drops of the combustion head and gas butterfly valve, on the basis of the burner operating output.

| | kW | Δp (mbar) | |
|--------|------|-----------|-----|
| | | 1 | 2 |
| RS 70 | 465 | 4.2 | 0.2 |
| | 515 | 4.8 | 0.2 |
| | 565 | 5.6 | 0.3 |
| | 615 | 6.4 | 0.3 |
| | 665 | 7.3 | 0.3 |
| | 715 | 8.3 | 0.4 |
| | 765 | 9.3 | 0.4 |
| | 814 | 10.3 | 0.4 |
| RS 100 | 695 | 3.7 | 0.4 |
| | 760 | 4.2 | 0.4 |
| | 825 | 5.0 | 0.5 |
| | 890 | 5.8 | 0.5 |
| | 955 | 6.5 | 0.6 |
| | 1020 | 7.3 | 0.7 |
| | 1085 | 8.3 | 0.8 |
| | 1163 | 9.3 | 0.8 |
| RS 130 | 930 | 3.8 | 1.0 |
| | 1010 | 4.5 | 1.1 |
| | 1090 | 5.1 | 1.3 |
| | 1170 | 5.8 | 1.5 |
| | 1250 | 6.5 | 1.7 |
| | 1330 | 7.2 | 1.8 |
| | 1410 | 7.9 | 1.9 |
| | 1512 | 8.6 | 2.0 |

Tab. G



The heat output and gas pressure data in the head refer to operation with gas butterfly valve fully open (90°).

The values shown in refer to:

- Natural gas G 20 NCV 10 kWh/Sm³ (8.6 Mcal/Sm³).

Column 1

Combustion head pressure drop.

Gas pressure measured at the test point 1)(Fig. 22), with:

- combustion chamber at 0 mbar;
- burner working at maximum output

Column 2

Pressure loss at gas butterfly valve 2)(Fig. 22) with maximum opening: 90°.

To calculate the approximate output at which the burner operates in the 2nd stage:

- subtract the combustion chamber pressure from the gas pressure measured at test point 1)(Fig. 22).
- Find, in Tab. G on page 21 related to the burner concerned, the pressure value closest to the result of the subtraction.
- Read the corresponding output on the left.

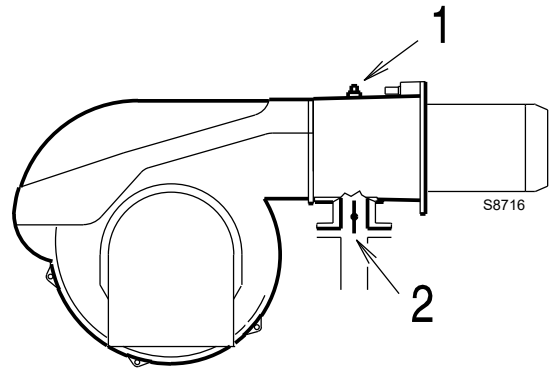

Fig. 22

Example - RS 100:

2nd stage operation

Natural gas G 20 NCV 10 kWh/Nm³

Gas ring nut 2)(Fig. 15 on page 19) adjusted as in the diagram (Fig. 16 on page 19).

| | | |
|--|---|----------|
| Gas pressure at test point 1)(Fig. 22) | = | 8.0 mbar |
| Pressure in combustion chamber | = | 3.0 mbar |
| $8.0 - 3.0$ | = | 5.0 mbar |

A pressure of 5 mbar, column 1, corresponds in the table RS 100 to an output in the 2nd stage of 825 kW.

This value serves as a rough guide; the effective output must be measured at the gas meter.

To calculate the required gas pressure at test point 1)(Fig. 22), set the maximum modulating output required from the burner operation:

- find the nearest output value in Tab. G on page 21 for the burner in question.
- Read, on the right (column 1), the pressure at the test point 1) (Fig. 22).
- Add this value to the estimated pressure in combustion chamber.

Example - RS 100:

Desired output in 2nd stage: 825 kW

Natural gas G 20 NCV 10 kWh/Nm³

Gas ring nut 2)(Fig. 15 on page 19) adjusted as in the diagram (Fig. 16 on page 19).

| | | |
|-------------------------------------|---|----------|
| Gas pressure at an output of 825 kW | = | 5.0 mbar |
| Pressure in combustion chamber | = | 3.0 mbar |
| $5.0 + 3.0$ | = | 8.0 mbar |

pressure required at test point 1)(Fig. 22).

5.10 Electrical wiring

Notes on safety for the electrical wiring



- The electrical wiring must be carried out with the electrical supply disconnected.
- Electrical wiring must be made in accordance with the regulations currently in force in the country of destination and by qualified personnel. Refer to the wiring diagrams.
- The manufacturer declines all responsibility for modifications or connections different from those shown in the wiring diagrams.
- Check that the electrical supply of the burner corresponds to that shown on the identification label and in this manual.
- The burner has been type-approved for intermittent use.
This means they should compulsorily be stopped at least once every 24 hours to enable the control box to perform checks of its own start-up efficiency. Normally, burner stopping is guaranteed by the boiler's thermostat/pressure switch.
- If this is not the case, a time switch should be fitted in series to TL to stop the burner at least once every 24 hours. Refer to the wiring diagrams.
- The electrical safety of the device is obtained only when it is correctly connected to an efficient earthing system, made according to current standards. It is necessary to check this fundamental safety requirement. In the event of doubt, have the electrical system checked by qualified personnel. Do not use the gas tubes as an earthing system for electrical devices.
- The electrical system must be suitable for the maximum power absorption of the device, as indicated on the label and in the manual, checking in particular that the section of the cables is suitable for that level of power absorption.
- For the main power supply of the device from the electricity mains:
 - do not use adapters, multiple sockets or extensions;
 - use a multiple pole switch with at least a 3 mm gap between the contacts (overvoltage category III), as envisaged by the present safety standards.
- Do not touch the device with wet or damp body parts and/or in bare feet.
- Do not pull the electric cables.

Before carrying out any maintenance, cleaning or checking operations:



Disconnect the electrical supply from the burner by means of the main system switch.



Close the fuel interception tap.



Avoid condensate, ice and water leaks from forming.

If the hood is still present, remove it and proceed with the electrical wiring according to the wiring diagrams.

Use flexible cables in compliance with the EN 60 335-1 standard.



After carrying out maintenance, cleaning or checking operations, reassemble the cover and all the safety and protection devices of the burner.

5.10.1 Supply cables and external connections passage

All the cables to be connected to the terminal board 10)(Fig. 23) of the burner must be threaded through cable grommets.

The use of the cable grommets and the pre-blanked holes can be done in different manners; by way of example we indicate the following mode (Fig. 23):

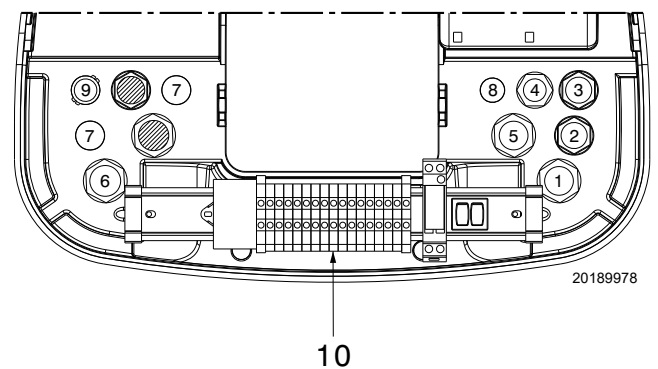

20189978

Fig. 23

Key to layout (Fig. 23)

- | | | |
|---|---------|---|
| 1 | Pg 13.5 | Three-phase power supply |
| 2 | Pg 11 | Gas valves (6 pole socket) |
| 3 | Pg 11 | One-phase power supply + Remote control device TL (7 pole socket) |
| 4 | Pg 9 | Remote control TR (4 pole socket) |
| 5 | Pg 13.5 | Available |
| 6 | Pg 13.5 | Gas pressure switch or gas valve leak detection control device |
| 7 | Pg 11 | Open the hole, if a pipe union is to be added |
| 8 | Pg 9 | Open the hole, if a pipe union is to be added |
| 9 | Pg 11 | Available |

5.11 Calibration of the thermal relay

The thermal relay serves to avoid damage to the motor due to an excessive absorption increase or if a phase is missing.

For the calibration, act on the wiper 2)(Fig. 24) by referring to the wiring diagram.

In case of burner lock-out, due to the thermal relay, press the button 1)(Fig. 24).



The automatic reset can be dangerous.
This operation is not foreseen in the burner operation.

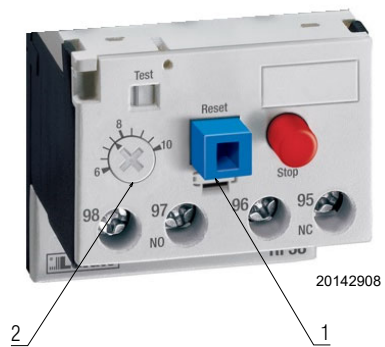

Fig. 24

5.12 Measuring the ionisation current

The burner is fitted with an ionisation system to check that a flame is present.

The minimum current for control box operation is 6 μ A.

The burner provides a much higher current, so controls are not normally required.

If it is necessary, however, to measure the ionisation current, disconnect the plug-socket 2)(Fig. 25) on the ionisation probe cable and insert a direct current microammeter 1)(Fig. 25) with a base scale of 100 μ A.



Carefully check the polarities!

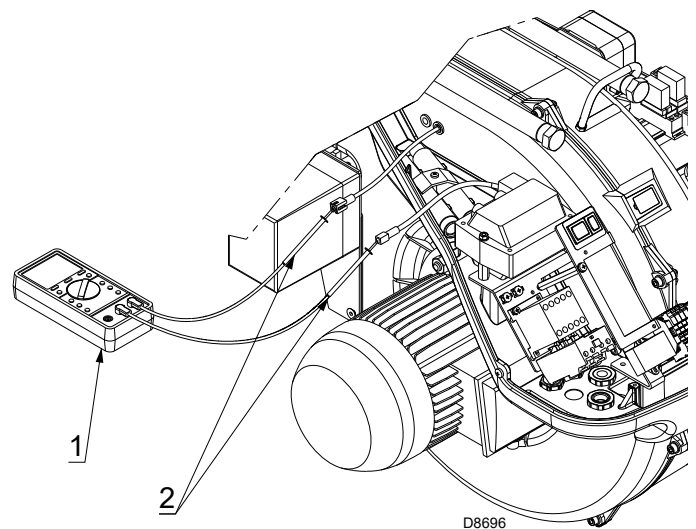

Fig. 25

6 Start-up, calibration and operation of the burner

6.1 Notes on safety for the first start-up



WARNING

The first start-up of the burner must be carried out by qualified personnel, as indicated in this manual and in compliance with the standards and regulations of the laws in force.



WARNING

Refer to paragraph “Safety test - with gas feeding closed” on page 32 before the first start-up.



WARNING

Check the correct working of the adjustment, command and safety devices.

6.2 Adjustments prior to ignition

Combustion head adjustment is already described on page 19.

In addition, the following adjustments must also be made:

- open the manual valves upline of the gas train.
- Adjust the minimum gas pressure switch to the start of the scale (Fig. 34).
- Adjust the air pressure switch to the start of the scale (Fig. 33).
- Purge the air from the gas line. We recommend using a plastic tube routed outside the building and to purge air until gas is smelt.
- Fit a U-type pressure gauge (Fig. 26) to the gas pressure test point on the pipe coupling.
- Used to obtain the approximate burner output in the 2nd stage using the Tab. G on page 21.
- Connect two lamps or testers parallel to the two gas line solenoid valves VR1 and VS in order to check the exact moment at which voltage is supplied. This operation is unnecessary if each of the two solenoid valves is equipped with a pilot light that signals voltage passing through.



CAUTION

Before starting up the burner, it is good practice to adjust the gas train so that ignition takes place in conditions of maximum safety, i.e. with gas delivery at the minimum.

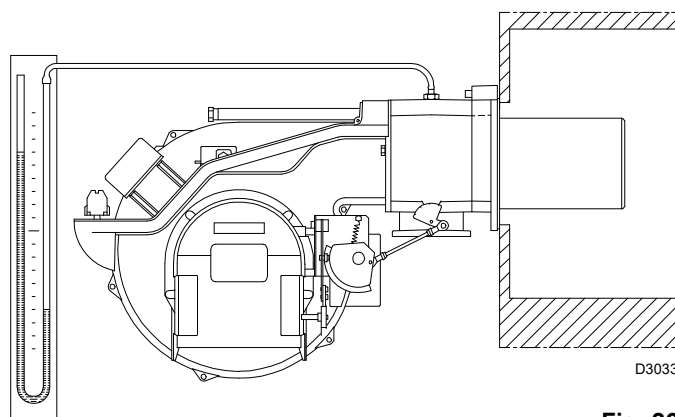

D3033

Fig. 26

6.3 Burner start-up

Feed electricity to the burner via the disconnecting switch on the boiler panel.

Close the remote controls and turn:

- switch 1)(Fig. 27) to the “Burner ON” position;
- switch 2)(Fig. 27) to the “1st stage” position.



WARNING

As soon as the burner starts up:

- check the fan rotation direction through the flame inspection window 13)(Fig. 4 on page 12).
- check the fan motor rotation direction, as shown in Fig. 28.



DANGER

Make sure that the lights or testers connected to the solenoids, or the pilot lights on the solenoids themselves, indicate that no voltage is present.

If voltage is present, stop the burner **immediately** and check the electrical wiring.

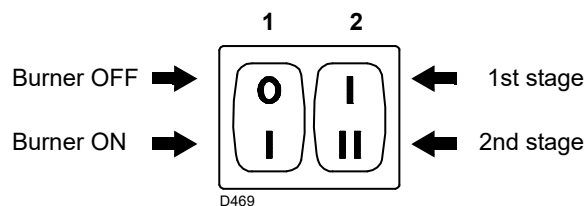
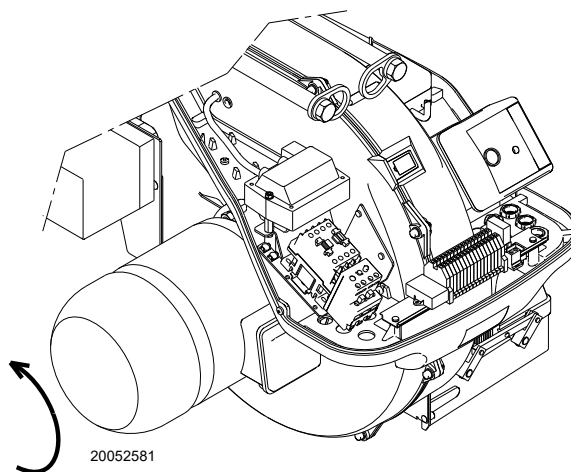

Fig. 27



20052581

Fig. 28

6.4 Servomotor adjustment

The servomotor (Fig. 29) simultaneously adjusts the air damper (by means of the variable profile cam) and the gas butterfly valve. The servomotor rotates by 90° in 12 seconds.



WARNING

Do not alter the factory setting for the 4 cams; check only that they are as shown below.

- Cam I:** 90°
Limits rotation toward maximum position. When the burner is at MAX output, the gas butterfly valve must be fully open: 90°.
- Cam II:** 0°
Limits rotation toward minimum position. When the burner is shut down, the air damper and gas butterfly valve must be closed: 0°.
- Cam III:** 30°
Adjusts the firing and output position in 1st stage.
- Cam IV:** 85°
Output signal for 2nd stage and/or hour counter.

NOTE:

The servomotor follows the adjustment of the black and orange lever when the angle of the cam is reduced.

- If the angle needs to be increased, pass to the 2nd stage and increase the angle, then return to the 1st stage to check the effect of the adjustment.
- For any necessary adjustment of cam III, use the screwdriver 11)(Fig. 31).
- For any necessary adjustment of cam IV, use the specific key 10)(Fig. 30) place inside the servomotor.

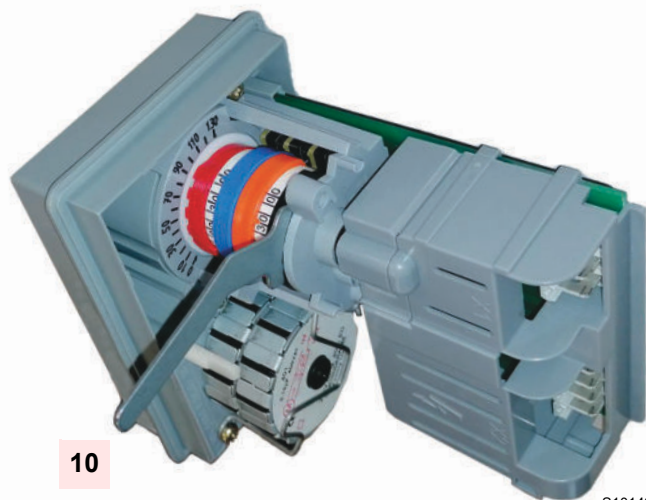

S10142

Fig. 30

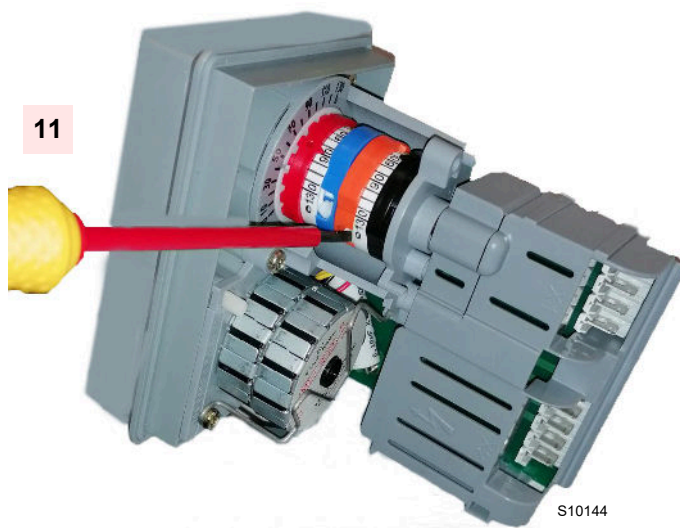

S10144

Fig. 31

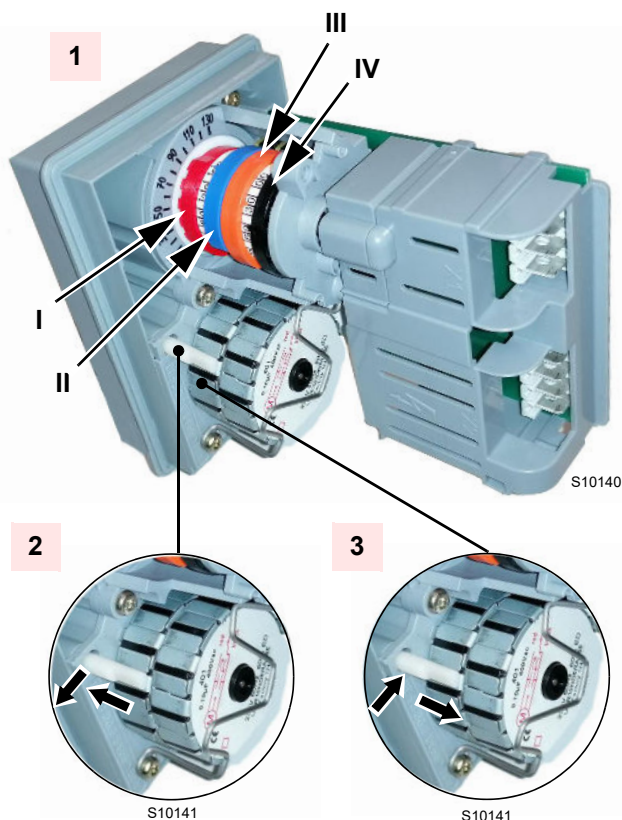

S10141

S10141

Fig. 29

Key

- 1 Servomotor
- 2 Servomotor 1) - cam 4): constrained
- 3 Servomotor 1) - cam 4): released
- 10 Spanner for adjusting cam IV (Fig. 30)
- 11 Screw driver for adjusting cam III (Fig. 31)

6.5 Burner ignition

Having completed the checks indicated in the previous heading, ignition of the burner should be achieved.

If the motor starts but the flame does not appear and the control box goes into lockout, reset and wait for a new start-up attempt.

If ignition is still not achieved, it may be that gas is not reaching the combustion head within the safety time period of 3 seconds. In this case, increase gas ignition delivery.

6.6 Adjusting the burner

The optimum adjustment of the burner requires an analysis of flue gases at the boiler outlet.

Adjust in sequence:

- 1 Burner output in 2nd stage
- 2 Burner output in 1st stage
- 3 Ignition output
- 4 Air pressure switch
- 5 Minimum gas pressure switch

6.6.1 Ignition output

According to EN 676:

Burners with MAX output up to 120 kW

Ignition can occur at the maximum operation output level. Example:

- max. operation output: 120 kW
- max. ignition output: 120 kW

Burners with MAX output above 120 kW

Ignition must occur at a lower output than the max. operation output.

If ignition output does not exceed 120 kW, no calculations are required. If ignition output exceeds 120 kW, the regulatory standard sets that the value be defined according to the control box safety time "ts":

- for "ts" = 2s, ignition output must be equal to or lower than 1/2 of max. operation output;
- for "ts" = 3s, ignition output must be equal to or less than 1/3 of the max. operation output.

Example:

MAX operation output of 600 kW.

Ignition output must be equal to or lower than:

- 300 kW con ts = 2s
- 200 kW con ts = 3s

In order to measure the ignition output:

- Remove the flame sensor (the burner comes on and goes into lockout after the safety time).
- Perform 10 ignitions with consecutive lockouts.
- Read the quantity of gas burned on the meter. This quantity must be equal to or lower than the quantity given by the formula:

$$\frac{\text{Nm}^3/\text{h (max. burner delivery)}}{360}$$

Example for G 20 gas (10 kWh/Nm³):

Max operation output, 600 kW

corresponding to 60 Nm³/h.

The arrival of gas to the pipe coupling is shown by the pressure gauge.

Once the burner has fired, now proceed with global calibration operations.

After 10 ignitions with their lockouts, the delivery indicated on the meter must be equal to or less than:

$$60 : 360 = 0.166 \text{ Nm}^3.$$

6.6.2 Output in 2nd stage

The output in the 2nd stage must be selected from within the firing rate range shown on page 10.

In the above description, we left the burner running, operating in the 1st stage.

Turn switch 2)(Fig. 27) to the 2nd stage position: the servomotor will open the air damper and, at the same time, also the gas butterfly valve opens at 90°.

Adjustment of gas delivery

Measure the gas delivery on the gas meter.

A rough indication can be obtained from the tables on page 21, just read the gas pressure on the U-shaped pressure gauge, see Fig. 26 on page 25), and follow the instructions on page 21.

If delivery needs to be reduced, diminish outlet gas pressure; if it is already very low, slightly close the VR adjustment valve.

If delivery needs to be increased, increase outlet gas pressure.

Air adjustment

Progressively adjust the end profile of cam 3)(Fig. 32) by turning the screws 5).

Turn the screws clockwise to increase air delivery.

Turn the screws anticlockwise to reduce air delivery.

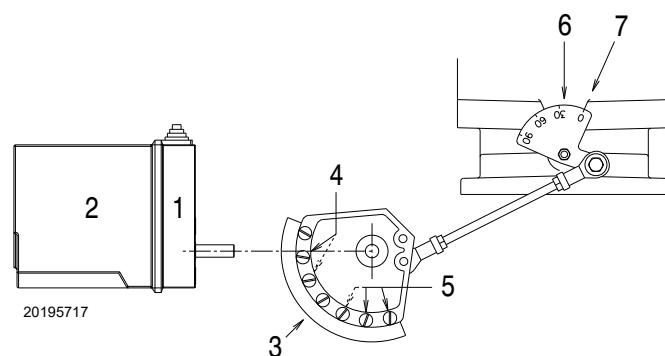

Fig. 32

- 1 Servomotor
- 2 Cam cover
- 3 Variable profile cam
- 4 Screws for adjusting the adjustable profile
- 5 Screws for adjusting the end profile
- 6 Graduated sector for gas butterfly valve
- 7 Index for graduated sector 6

6.6.3 Output in 1st stage

The 1st stage output must be selected from within the firing rate range shown on page 10.

Turn the switch 2)(Fig. 27 on page 25) to the 1st stage position: the servomotor 1)(Fig. 32) will close the air damper and, at the same time, also the gas butterfly valve closes to 15°, i.e. to the factory setting.

Adjustment of gas delivery

Measure the gas delivery on the gas meter.

- If it is necessary to decrease it, slightly decrease the angle of the orange lever (Fig. 31 on page 26) namely from angle 15° to 13° - 11°....
- If it is necessary to increase it, pass to 2nd stage by activating the switch 2)(Fig. 27 on page 25) and slightly increase the angle of the orange lever with small, regular movements, i.e. bring it from an angle of 15° to 17° - 19°....

Now return to the 1st stage and measure the gas output.

NOTE:

The servomotor only follows the adjustment of the orange lever when the angle of the cam is reduced.

If the angle needs to be increased, pass to the 2nd stage, increase the angle and then return to the 1st stage to check the effects of the adjustment.

Adjustment of air delivery

Progressively adjust the initial profile of the cam 3)(Fig. 32) by turning the screws 4).

It is preferable not to turn the first screw since this is used to set the air damper to its fully closed position.

6.7 Pressure switch adjustment

6.7.1 Air pressure switch

Adjust the air pressure switch after performing all other burner adjustments with the air pressure switch set to the start of the scale (Fig. 33).

With the burner operating in the 1st stage, increase adjustment pressure by slowly turning the relative knob clockwise until the burner locks out.

Then turn the knob anti-clockwise by about 20% of the set point and repeat burner starting to ensure it is correct.

If the burner locks out again, turn the knob anti-clockwise a little bit more.



In conformity with the standard, the air pressure switch must prevent the CO in the flue gases from exceeding 1% (10,000 ppm).

To check this, insert a combustion analyser into the chimney, slowly close the fan suction inlet (for example with cardboard) and check that the burner locks out, before the CO in the fumes exceeds 1%.

The incorporated air pressure switch can work in a 'differential' mode if connected with two pipes. If a negative pressure in the combustion chamber during pre-purging prevents the air pressure switch from switching.

Switching may be obtained by fitting a second pipe between the air pressure switch and the suction inlet of the fan. In such a manner the air pressure switch operates as differential pressure switch.



The use of the air pressure switch with differential operation is allowed only in industrial applications and where rules enable the air pressure switch to control only fan operation without any reference to CO limit.

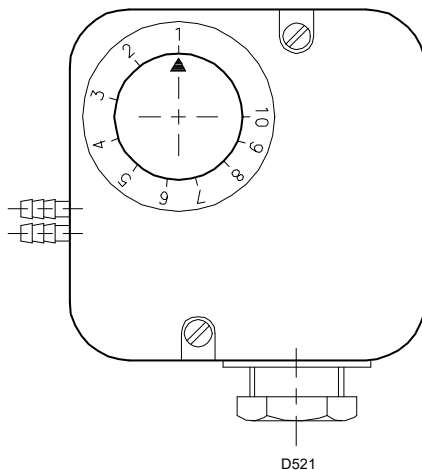

Fig. 33



1 kPa = 10 mbar

6.7.2 Minimum gas pressure switch

The purpose of the minimum gas pressure switch is to prevent the burner from operating in an unsuitable way due to too low gas pressure.

Adjust the minimum gas pressure switch (Fig. 34) after having adjusted the burner, the gas valves and the gas train stabiliser. With the burner operating at maximum output:

- install a pressure gauge downstream of the gas train stabiliser (for example at the gas pressure test point on the burner combustion head);
- choke slowly the manual gas cock until the pressure gauge detects a decrease in the pressure read of about 0.1 kPa (1 mbar). In this phase, verify the CO value which must always be less than 100 mg/kWh (93 ppm).
- Increase the adjustment of the gas pressure switch until it intervenes, causing the burner shutdown;
- remove the pressure gauge and close the cock of the gas pressure test point used for the measurement; open completely the manual gas cock.

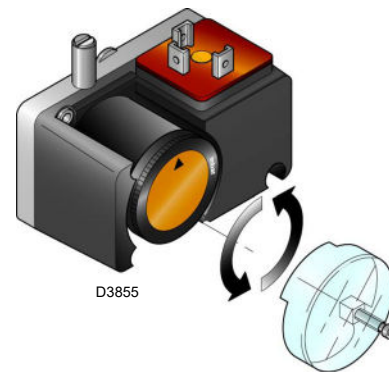

Fig. 34

6.8 Operation sequence of the burner

6.8.1 Burner start-up

Control remote control TL closes (Fig. 35).

Servomotor starts: turn to the right, as far as the angle set on the cam with the orange lever.

After about 3s:

- 0 s The control box program starts up.
- 2 s The fan motor starts up.
- 3 s The servomotor starts up: turn to the right, until the contact intervenes on the cam with the red lever. The air damper goes to 2nd stage output. Pre-purging phase with air flow rate at 2nd stage output level. Duration 25 s.
- 28 s The servomotor starts up: turn to the left, as far as the angle set on the cam with the orange lever.
- 36 s The ignition electrode strikes a spark. The air damper and gas butterfly valve are at 1st stage output level. The safety valve VS opens, along with the adjustment valve VR, quick opening. The flame ignites with a small output - point A. The output gradually increases, and the valve slowly opens, until 1st stage output is reached - point B.
- 38 s The spark goes out.
- 46 s If the TR remote control is closed or replace with a jumper, the servomotor goes on rotating until the cam intervenes with the red lever, bring the air damper and gas butterfly valve to the 2nd stage - tract C-D.

6.8.2 Operation

System equipped with TR remote control (Fig. 35)

Once the start-up cycle is completed, the servomotor command moves on to the TR remote control, that controls the pressure or temperature in the boiler - point D.

(The control box still continues to check the presence of the flame and the correct position of the air pressure switch).

- When the temperature or pressure increases and opens the TR, the servomotor closes the gas butterfly valve and air damper, and the burner goes from the 2nd to the 1st operating stage - tract E/F.
- When the temperature or pressure falls and closes the TR, the servomotor opens the gas butterfly valve and air damper, and the burner goes from the 1st to the 2nd operating stage. The sequence repeats endlessly.
- The burner stops when the heat request is less than the amount of heat delivered by the burner in the 1st stage, tract G-H. The TL remote control opens, and the servomotor returns to the 0° angle (limited by the cam with the light blue lever). The air damper closes completely to reduce heat losses to a minimum.

System not equipped with TR (replaced with jumper) (Fig. 35)

The burner is fired as described above. If the temperature or pressure increases until the TL opens, the burner shuts down (tract A-A in diagram Fig. 35).

NORMAL IGNITION
(n° = seconds from instant 0)

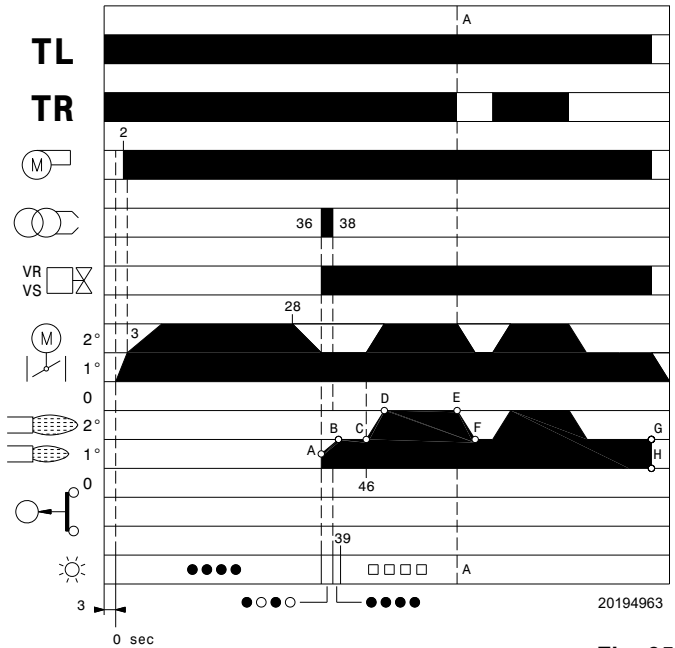

Fig. 35

RMG LED

- Off
- Yellow
- Green
- ▲ Red

6.8.3 Ignition failure

If the burner does not fire, it goes into lockout within 3s of the opening of the gas valve and within 42s of the closure of the TL remote control (Fig. 36).

The red LED of the control box comes on.

NO IGNITION

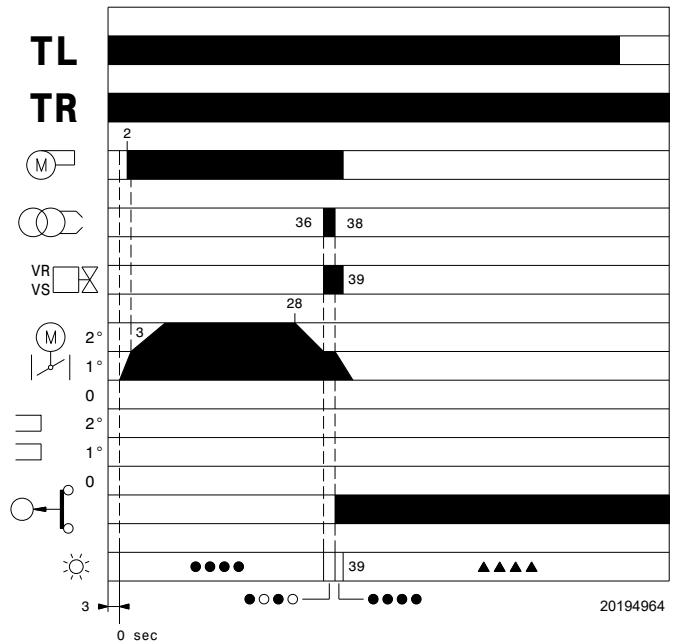

Fig. 36

6.8.4 Burner flame goes out during operation

If the flame accidentally goes out during operation, the burner will go into lockout within 1s.

6.9 Stopping of the burner

The burner can be stopped by:

- intervening on the disconnecting switch of the electrical supply line, located on the boiler panel;
- removing the casing and intervening on the switch (Fig. 27 on page 25).



Carry out all the operations, then reassemble the hood and all the burner safety and protection devices.

6.10 Final checks (with burner operating)

| | | |
|---|--|---|
| <ul style="list-style-type: none"> ➤ Open the thermostat/pressure switch TL ➤ Open the thermostat/pressure switch TS | | The burner must stop |
| <ul style="list-style-type: none"> ➤ Turn the air pressure switch to the maximum end of scale position | | The burner must stop in lockout |
| <ul style="list-style-type: none"> ➤ Turn off the burner and cut off the power ➤ Disconnect the minimum gas pressure switch connector | | The burner must not start |
| <ul style="list-style-type: none"> ➤ Disconnect the wire of the ionisation probe | | The burner must stop in lockout due to ignition failure |

Tab. H



Make sure that the mechanical locking systems on the various adjustment devices are fully tightened.

7 Maintenance

7.1 Notes on safety for the maintenance

The periodic maintenance is essential for the good operation, safety, yield and duration of the burner.

It allows you to reduce consumption and polluting emissions and to keep the product in a reliable state over time.



The maintenance interventions and the calibration of the burner must only be carried out by qualified, authorised personnel, in accordance with the contents of this manual and in compliance with the standards and regulations of current laws.

Before carrying out any maintenance, cleaning or checking operations:



Disconnect the electrical supply from the burner by means of the main system switch.



Close the fuel interception tap.



Wait for the components in contact with heat sources to cool down completely.

7.2 Maintenance programme

7.2.1 Maintenance frequency



The gas combustion system should be checked at least once a year by a representative of the manufacturer or another specialised technician.

7.2.2 Safety test - with gas feeding closed

For its safe commissioning it is very important to make sure that the electrical wiring has been carried out correctly between the gas valves and the burner.

To this end, after checking that the connections have been made in conformity with the burner's wiring diagram, a starting cycle should be carried out with the gas tap closed (dry test).

- 1 The manual gas valve should be closed with the locking/releasing device ("lock-out / tag out" procedure).
- 2 Make sure the limit electric contacts of the burner close
- 3 Make sure the contact of the minimum gas pressure switch closes
- 4 Proceed with a tentative start up of the burner.

The starting cycle should occur with the following phases:

- Starting the fan motor for pre-purging
- Carrying out the gas valve leak detection control, if applicable
- Completing the pre-purging
- Reaching the ignition point
- Power supply of the ignition transformer
- Power supply the gas valves.

Since the gas is closed, the burner will not be able to start and its control box will stop or go into a safety lockout.

The effective supplying of the gas valves can be checked with the insertion of a tester; some valves are fitted with light signals (or closure/opening position indicators) that are activated when the electrical supply arrives.



IF THE ELECTRICAL SUPPLY OF THE GAS VALVES OCCURS AT AN UNEXPECTED MOMENT, DO NOT OPEN THE MANUAL VALVE, DISCONNECT THE ELECTRICAL SUPPLY, CHECK THE WIRING; CORRECT THE ERRORS AND CARRY OUT THE ENTIRE TEST AGAIN.

7.2.3 Checking and cleaning



The operator must use the required equipment during maintenance.

Combustion head

Open the burner and make sure that all components of the combustion head are in good condition, not deformed by the high temperatures, free of impurities from the surroundings and correctly positioned.

Gas filter

Change the gas filter when it is dirty.

Burner

Check that there are not excess wear or loosen screws. The screws securing the electrical leads in the burner plugs should also be fully tightened.

Clean the outside of the burner.

Clean and grease the adjustable profile of the cams.

Fan

Check to make sure that no dust has accumulated inside the fan or on its impellers, as this condition will cause a reduction in the air flow rate and provoke polluting combustion.

Boiler

Clean the boiler as indicated in its accompanying instructions in order to maintain all the original combustion characteristics intact, especially: the flue gas temperature and combustion chamber pressure.

Gas leaks

Make sure that there are no gas leaks on the pipe between the gas meter and the burner.

Flame inspection window

Clean the glass of the flame inspection window.

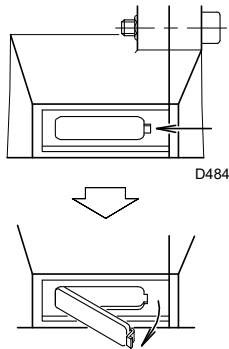

Fig. 37

7.2.4 Combustion control (gas)

The optimum calibration of the burner requires an analysis of the flue gases.

Significant differences with respect to the previous measurements indicate the points where more care should be exercised during maintenance.

In case the combustion values found at the beginning of the intervention do not respect the standards in force or, in any case, do not correspond to a proper combustion, contact the Technical Assistance Centre in order to carry out the necessary adjustments.

| EN 676 | | Air excess | | CO |
|--------|---|-----------------------------------|-----------------------------------|------------|
| | | Max. output $\lambda \leq 1.2$ | Max. output $\lambda \leq 1.3$ | |
| GAS | Theoretical max CO ₂ 0 % O ₂ | CO ₂ % Calibration | | mg/kWh |
| | | $\lambda = 1.2$ | $\lambda = 1.3$ | |
| G 20 | 11.7 | 9.7 | 9 | ≤ 100 |
| G 25 | 11.5 | 9.5 | 8.8 | ≤ 100 |

Tab. I

CO₂

It is advisable to adjust the burner with a CO₂ not greater than about 10% (gas con Ncv 8600 kcal/m³). In this way it is avoided that a small decalibration (for example a variation in the tension) could cause a combustion with an air defect and with the subsequent formation of CO.

CO

It should not exceed 100 mg/kWh.

7.2.5 Safety components

The safety components should be replaced at the end of their life cycle indicated in Tab. J.

The specified life cycles do not refer to the warranty terms indicated in the delivery or payment conditions.

| Safety component | Life cycle |
|--|--------------------------------------|
| Flame control | 10 years or 250.000 operation cycles |
| Flame sensor | 10 years or 250.000 operation cycles |
| Gas valves (solenoid) | 10 years or 250.000 operation cycles |
| Pressure switches | 10 years or 250.000 operation cycles |
| Pressure adjuster | 15 years |
| Servomotor (electronic cam) (if present) | 10 years or 250.000 operation cycles |
| Oil valve (solenoid) (if present) | 10 years or 250.000 operation cycles |
| Oil regulator (if present) | 10 years or 250.000 operation cycles |
| Oil pipes/ couplings (metallic) (if present) | 10 years |
| Hoses (if present) | 5 years or 30.000 pressurised cycles |
| Fan impeller | 10 years or 500.000 start-ups |

Tab. J

7.2.6 Checking the air and gas pressure on the combustion head

To check the air and gas pressure on the burner pipe coupling, install the relative pressure gauges as shown in Fig. 38.

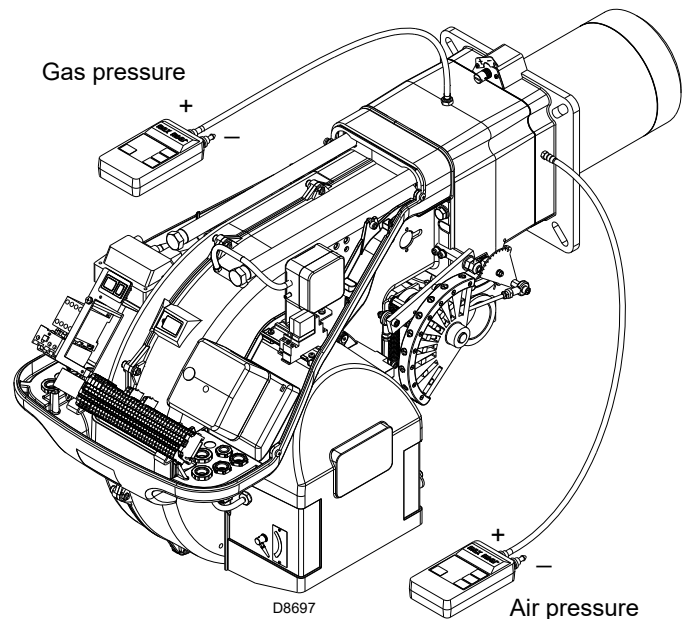

Fig. 38

7.3 Opening the burner



Disconnect the electrical supply from the burner by means of the main system switch.



Close the fuel interception tap.



Wait for the components in contact with heat sources to cool down completely.

- Loosen the screws 1) and remove the hood 2)(Fig. 39).
- Disengage the articulated coupling 7) from the graduated sector 8).
- Fit the two extension supplied onto the slide bars 4)(models with blast tube 503 mm).
- Remove the screws 3) and move the burner backwards by about 100 mm on the slide bars 4).
- Disconnect the probe and electrode leads and then pull the burner fully back.

Now it is possible to extract the gas distributor 5) after having removed the screw 6)(Fig. 39).

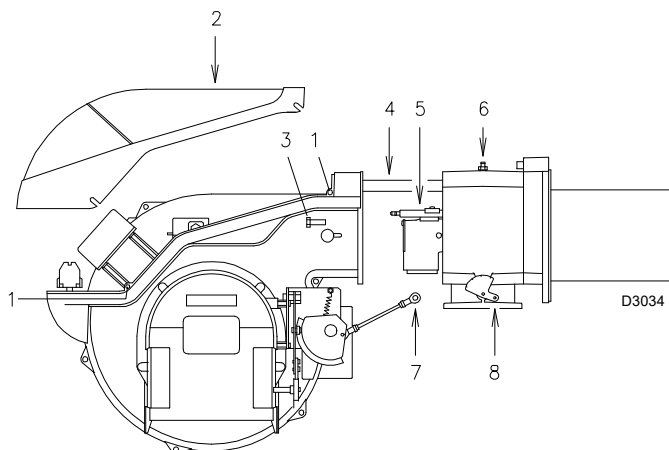

Fig. 39

7.4 Closing the burner

- Push the burner to approximately 100 mm from the pipe coupling.
- Reconnect the cables and slide in the burner until it comes to a stop.
- Replace the screws 3)(Fig. 39) and carefully pull the probe and electrode cables outwards until they are slightly taut.
- Reconnect the articulated coupling 7)(Fig. 39) to the graduated sector 8)(Fig. 39).
- Disassemble the two extensions from the slide bars 4)(Fig. 39).



After carrying out maintenance, cleaning or checking operations, reassemble the cover and all the safety and protection devices of the burner.

8 Faults - Possible causes - Solutions



In the event the burner stops, in order to prevent any damage to the installation, do not unblock the burner more than twice in a row. If the burner locks out for a third time, contact the customer service.



In the event there are further lockouts or faults with the burner, the maintenance interventions must only be carried out by qualified, authorised personnel, in accordance with the contents of this manual and in compliance with the standards and regulations of current laws.

| Signal | Problem | Possible cause | Recommended remedy |
|--|---|--|---|
| 2 blinks ●● | Once the pre-purging phase and safety time have passed, the burner goes into lockout without the appearance of the flame. | The operation solenoid lets little gas through. | Increase |
| | | One of the two solenoid valves does not open | Replace |
| | | Gas pressure too low | Increase pressure at governor |
| | | Ignition electrode incorrectly adjusted | Adjust it |
| | | Electrode grounded due to broken insulation | Replace |
| | | High voltage cable defective | Replace |
| | | High voltage cable deformed by high temperature | Replace and protect |
| | | Ignition transformer defective | Replace |
| | | Incorrect valve or transformer electrical wiring | Check |
| | | Defective control box | Replace |
| | | A closed valve upline the gas train | Open |
| | | Air in pipework | Bleed air |
| | | Gas valves unconnected or with interrupted coil | Check connections or replace coil |
| 3x flashes ●●● | The burner does not switch on, and the lockout appears | Air pressure switch in operating position | Adjust or replace |
| | The burner switches on, but then stops in lockout | Air pressure switch does not switch owing to lack of air pressure: | |
| | | Air pressure switch poorly adjusted | Adjust or replace |
| | | Pressure switch pressure point pipe blocked | Clean |
| | | Poorly adjusted head | Adjust |
| | | High pressure in the furnace | Connect air pressure switch to fan suction line |
| | Lockout during pre-purging phase | Defective motor control contactor (only three-phase version) | Replace |
| Defective electrical motor | | Replace | |
| Motor lockout (only three-phase version) | | Replace | |
| 4 blinks ●●●● | The burner switches on, but then stops in lockout | Flame simulation | Replace the control box |
| | Lockout when burner stops | Permanent flame in the combustion head or flame simulation | Eliminate persistence of flame or replace control box |
| 6 blinks ●●●●●● | The burner switches on, but then stops in lockout | Defective or incorrectly adjusted servomotor | Adjust or replace |
| 7 blinks ●●●●●●● | The burner goes into lockout immediately following the appearance of the flame | The operation solenoid lets little gas through | Increase |
| | | Ionisation probe incorrectly adjusted | Adjust |
| | | Insufficient ionisation (less than 5 A) | Check probe position |
| | | Earth probe | Withdraw or replace cable |
| | | Burner poorly earthed | Check earthing |
| | | Phase and neutral connections inverted | Invert them |
| | | Defective flame detection circuit | Replace the control box |
| | Burner locks out when shifting from minimum to maximum output and vice versa | Too much air or too little gas | Adjust air and gas |
| | Burner goes into lockout during operation | Probe or ionisation cable grounded | Replace worn parts |

| Signal | Problem | Possible cause | Recommended remedy |
|-----------------------------------|--|---|---|
| 10 blinks ●●●●●● ●●●●●● | The burner does not switch on, and the lock-out appears | Incorrect electrical wiring | Check |
| | The burner goes into lockout | Defective control box | Replace |
| | | Presence of electromagnetic disturbances in the thermostat lines | Filter or eliminate |
| | | Presence of electromagnetic disturbance | Use the radio disturbance protection kit |
| No blink | The burner does not start | No electrical power supply | Check connections |
| | | A limiter or safety control device is open | Adjust or replace |
| | | Line fuse blocked | Replace |
| | | Defective control box | Replace |
| | | No gas supply | Open the manual valves between contactor and train |
| | | Mains gas pressure insufficient | Contact your gas company |
| | | Minimum gas pressure switch fails to close | Adjust or replace |
| | | Servomotor fails to move to min. ignition position | Replace |
| | The burner continues to repeat the start-up cycle, without lockout | The gas pressure in the gas mains lies very close to the value to which the gas pressure switch has been set. The sudden drop in pressure after valve opening causes temporary opening of the pressure switch itself, the valve immediately closes and the burner comes to a halt. Pressure increases again, the pressure switch closes again and the ignition cycle is repeated. And so on | Reduce the minimum gas pressure switch intervention pressure. Replace the gas filter cartridge. |
| | Ignition with pulsations | Poorly adjusted head | Adjust |
| | | Ignition electrode incorrectly adjusted | Adjust it |
| | | Incorrectly adjusted fan air damper: too much air | Adjust |
| | | Output during ignition phase is too high | Reduce |
| | Burner does not reach maximum output | Remote control device TR fails to close | Adjust or replace |
| | | Defective control box | Replace |
| | | Defective servomotor | Replace |
| Burner stops with air damper open | Defective servomotor | Replace | |

Tab. K

A Appendix - Accessories**Kit for LPG operation**

| Burner | RS 70 | RS 100 | RS 130 |
|--------|---------------------|---------------------|---------------------|
| Code | 20008175 - 20008176 | 20008177 - 20008178 | 20008179 - 20008180 |

Vibration reduction kit

| Burner | RS 70 | RS 100 | RS 130 |
|--------|---------|---------|-------------------|
| Code | 3010201 | 3010202 | 3010373 - 3010374 |

Extended head kit

| Burner | RS 70 | RS 100 | RS 130 |
|--------|---------|---------|---------|
| Code | 3010117 | 3010118 | 3010119 |

DN 80 flange kit

| Burner | RS 70 - 100 - 130 |
|--------|-------------------|
| Code | 3010439 |

Town gas kit

| Burner | RS 70 | RS 100 | RS 130 |
|--------|---------|---------|---------|
| Code | 3010286 | 3010287 | 3010288 |

Clean contacts kit

| Burner | RS 70 - 100 - 130 |
|--------|-------------------|
| Code | 20123294 |

Sound proofing box kit

| Burner | RS 70 - 100 - 130 |
|--------|-------------------|
| Code | 3010404 |

Radio disturbance protection kit

If the burner is installed in places particularly subject to radio disturbance (emission of signals exceeding 10 V/m) owing to the presence of an INVERTER, or in applications where the length of the thermostat connections exceeds 20 metres, a protection kit is available as an interface between the control box and the burner.

Spacer kit

| Burner | RS 70 - 100 - 130 |
|--------|-------------------|
| Code | 3010129 |

| Burner | RS 70 - 100 - 130 |
|--------|-------------------|
| Code | 3010386 |

Continuous purging kit

| Burner | RS 70 - 100 - 130 |
|--------|-------------------|
| Code | 3010094 |

Gas trains in compliance with EN 676

Please refer to manual.



WARNING

The installer is responsible for the addition of any safety device not foreseen in this manual.

Differential circuit breaker kit

| Burner | RS 70 - 100 - 130 |
|--------|-------------------|
| Code | 3010329 |

Maximum gas pressure switch kit

| Burner | RS 70 - 100 - 130 |
|--------|-------------------|
| Code | 3010493 |

PC interface kit

| Burner | RS 70 - 100 - 130 |
|--------|-------------------|
| Code | 3002719 |

B Appendix - Electrical panel layout

| | |
|----------|---|
| 1 | Index of layouts |
| 2 | Indication of references |
| 3 | RS 70 Functional diagram RS 100 Functional diagram RS 130 Functional diagram |
| 4 | Functional diagram |
| 5 | RS 70 Electrical wiring that the installer is responsible for RS 100 Electrical wiring that the installer is responsible for RS 130 Electrical wiring that the installer is responsible for |

2 Indication of references

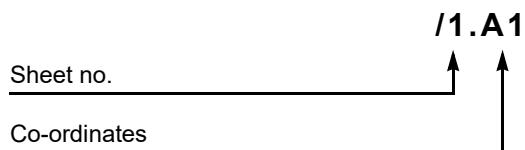

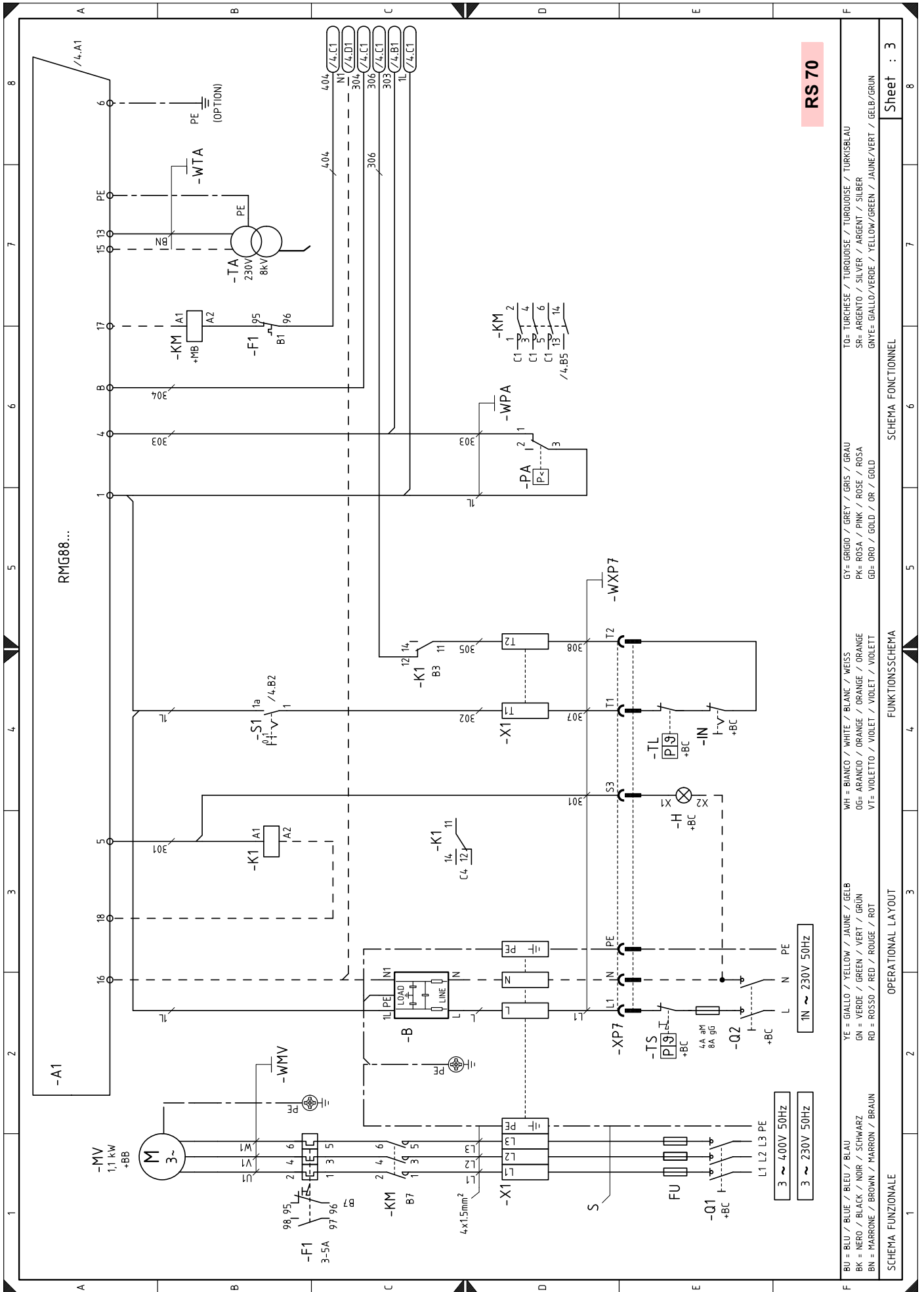

RS 70

TO= TURCHESE / TURQUOISE / TURQUOISE / TURQUOISE / TURQUOISE / TURKISBLAU
 SR= ARGENTO / SILVER / ARGENT / SILBER
 GNVE= GIALLO/VERDE / YELLOW/GREEN / JAUNE/VERT / GELB/GRUN

GY= GRIGIO / GREY / GRIS / GRAU
 PK= ROSA / PINK / ROSE / ROSA
 GD= ORO / GOLD / OR / GOLD

WH= BIANCO / WHITE / BLANC / WEISS
 OG= ARANCIO / ORANGE / ORANGE / ORANGE
 VT= VIOLETTA / VIOLET / VIOLET / VIOLETT

YE= GIALLO / YELLOW / JAUNE / GELB
 GN= VERDE / GREEN / VERT / GRUN
 RD= ROSSO / RED / ROUGE / ROT

BU= BLU / BLUE / BLEU / BLAU
 BK= NERO / BLACK / NOIR / SCHWARZ
 BN= MARRONE / BROWN / MARRON / BRAUN

SCHEMA FUNZIONALE OPERATIONAL LAYOUT

Sheet : 3

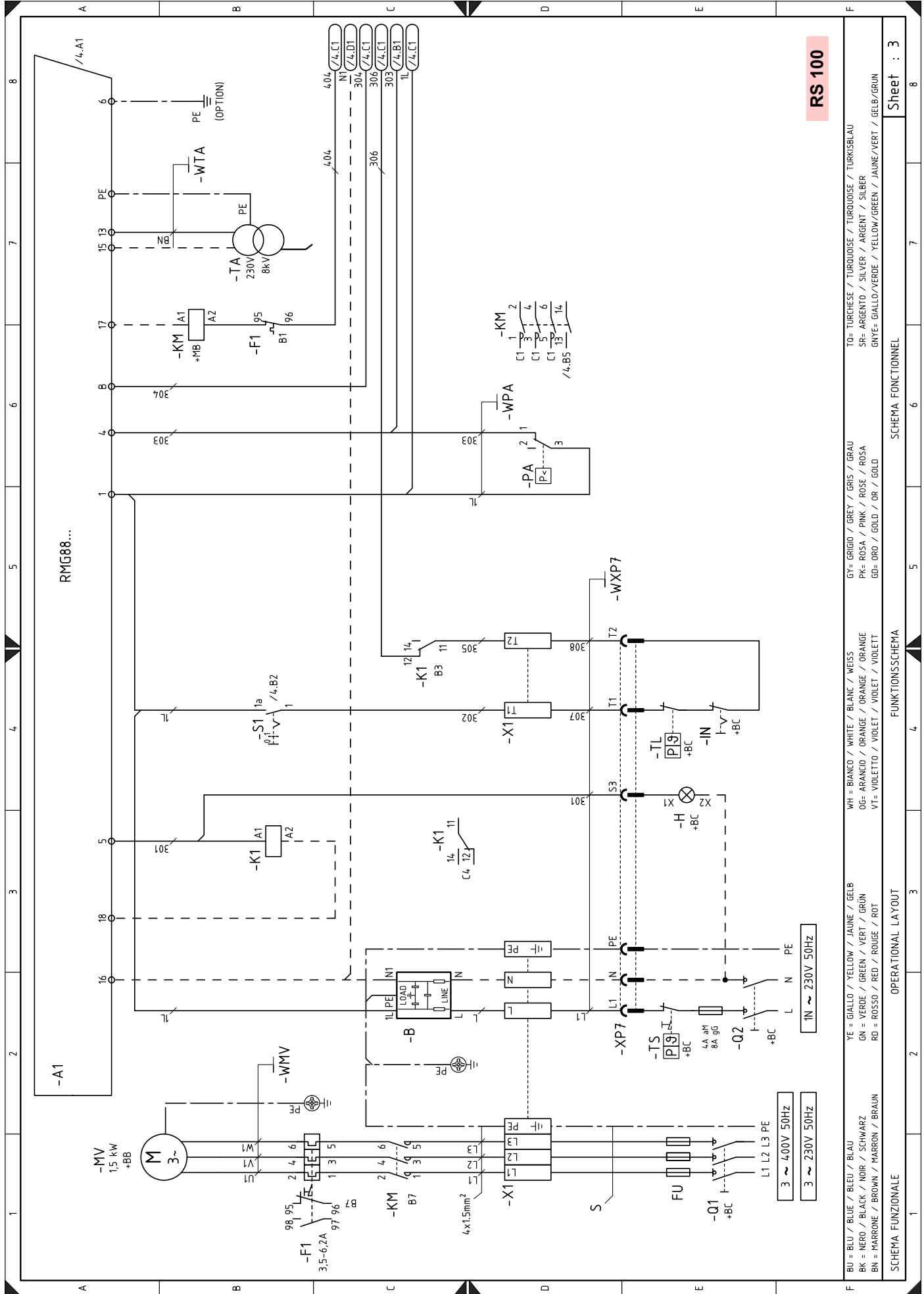

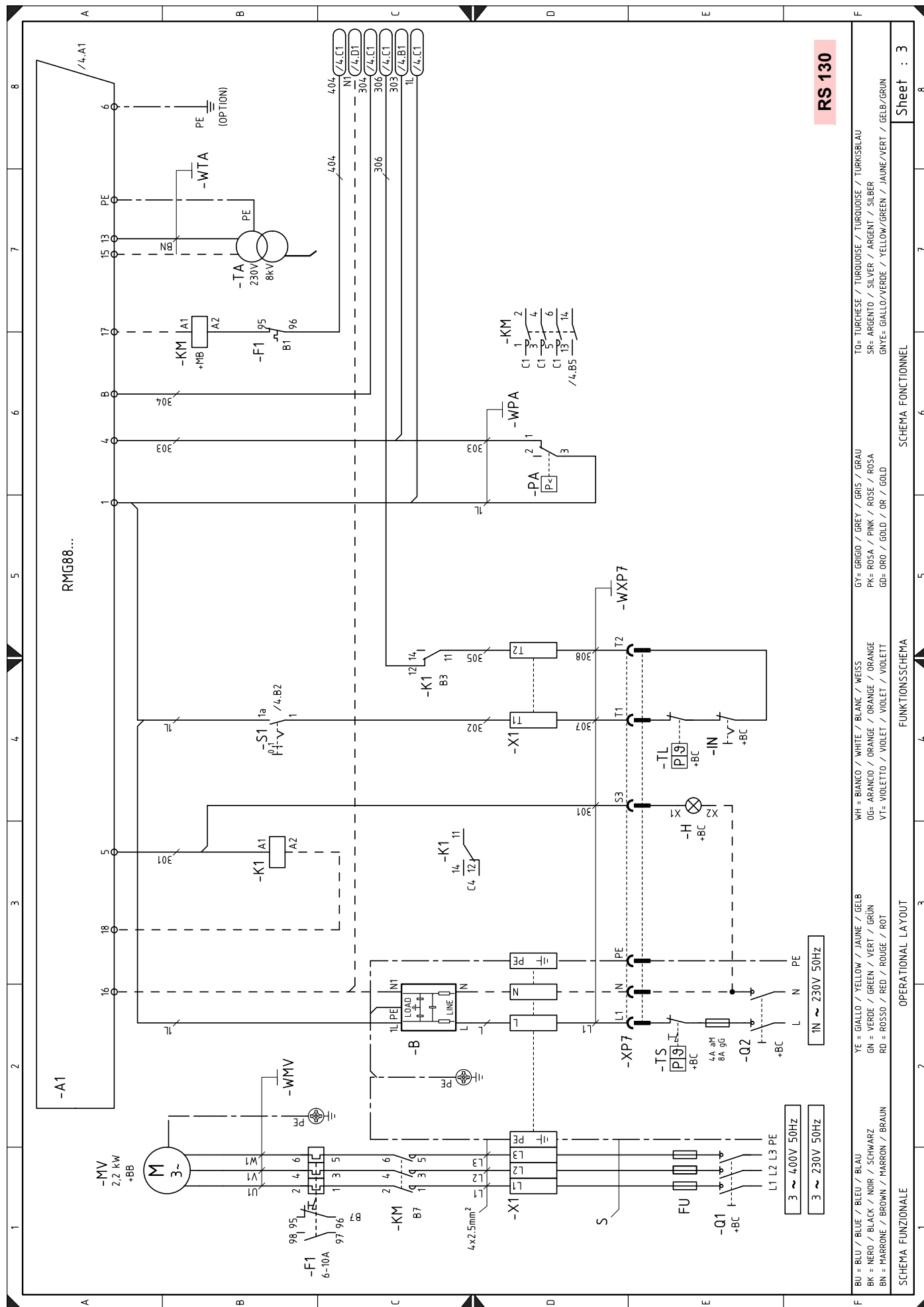

RS 130

Sheet : 3

SCHEMA FONCTIONNEL

FUNKTIONSSCHEMA

OPERATIONAL LAYOUT

SCHEMA FUNZIONALE

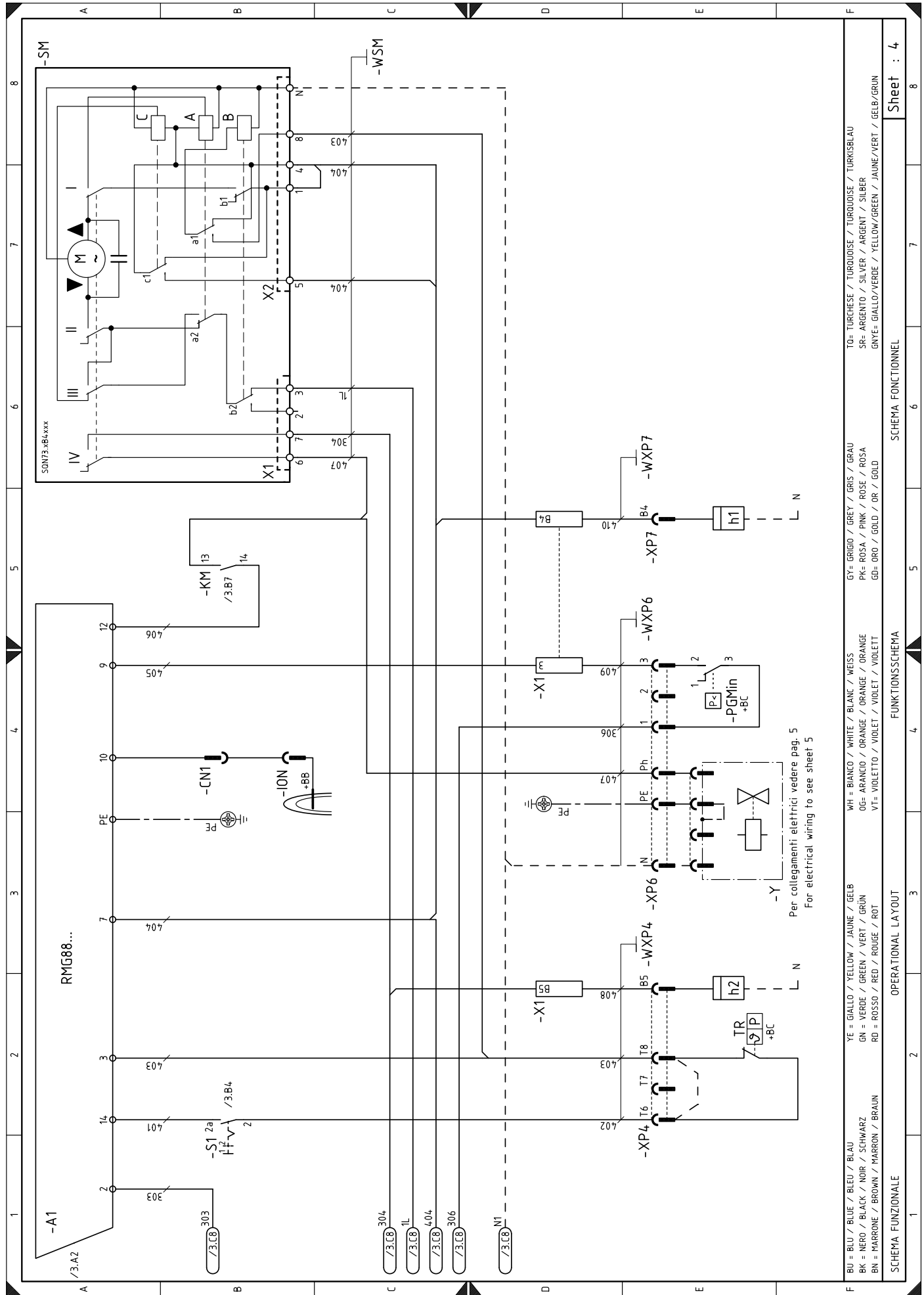

| | | | | |
|---------------------------------------|-------------------------------------|--|----------------------------------|--|
| BU = BLU / BLUE / BLEU / BLAU | YE = GIALLO / YELLOW / JAUNE / GELB | WH = BIANCO / WHITE / BLANC / WEISS | GY = GRIGIO / GREY / GRIS / GRAU | TO= TURCHESE / TURKOISE / TURKOISE / TURKISBLAU |
| BK = NERO / BLACK / NOIR / SCHWARZ | GN = VERDE / GREEN / VERT / GRÜN | OG= ARANCIO / ORANGE / ORANGE / ORANGE | PK= ROSA / PINK / ROSE / ROSA | SR= ARGENTO / SILVER / ARGENT / SILBER |
| BN = MARRONE / BROWN / MARRON / BRAUN | RD = ROSSO / RED / ROUGE / ROT | VT= VIOLETTA / VIOLET / VIOLET / VIOLETT | GD= ORO / GOLD / OR / GOLD | GNVE= GIALLO/VERDE / YELLOW/GREEN / JAUNE/VERT / GELB/GRÜN |

OPERATIONAL LAYOUT

FUNKTIONSSCHEMA

SCHEMA FONCTIONNEL

Sheet : 4

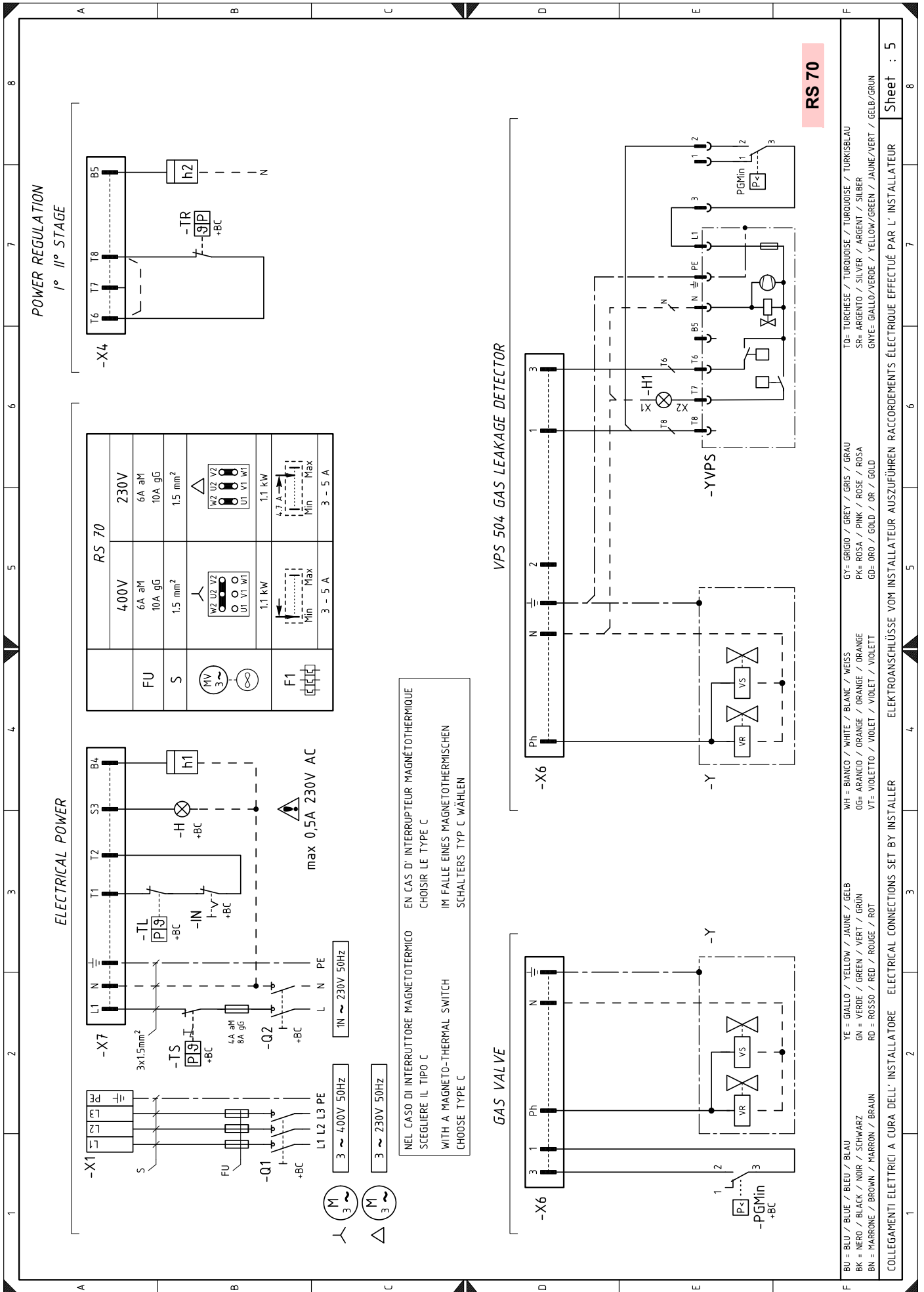

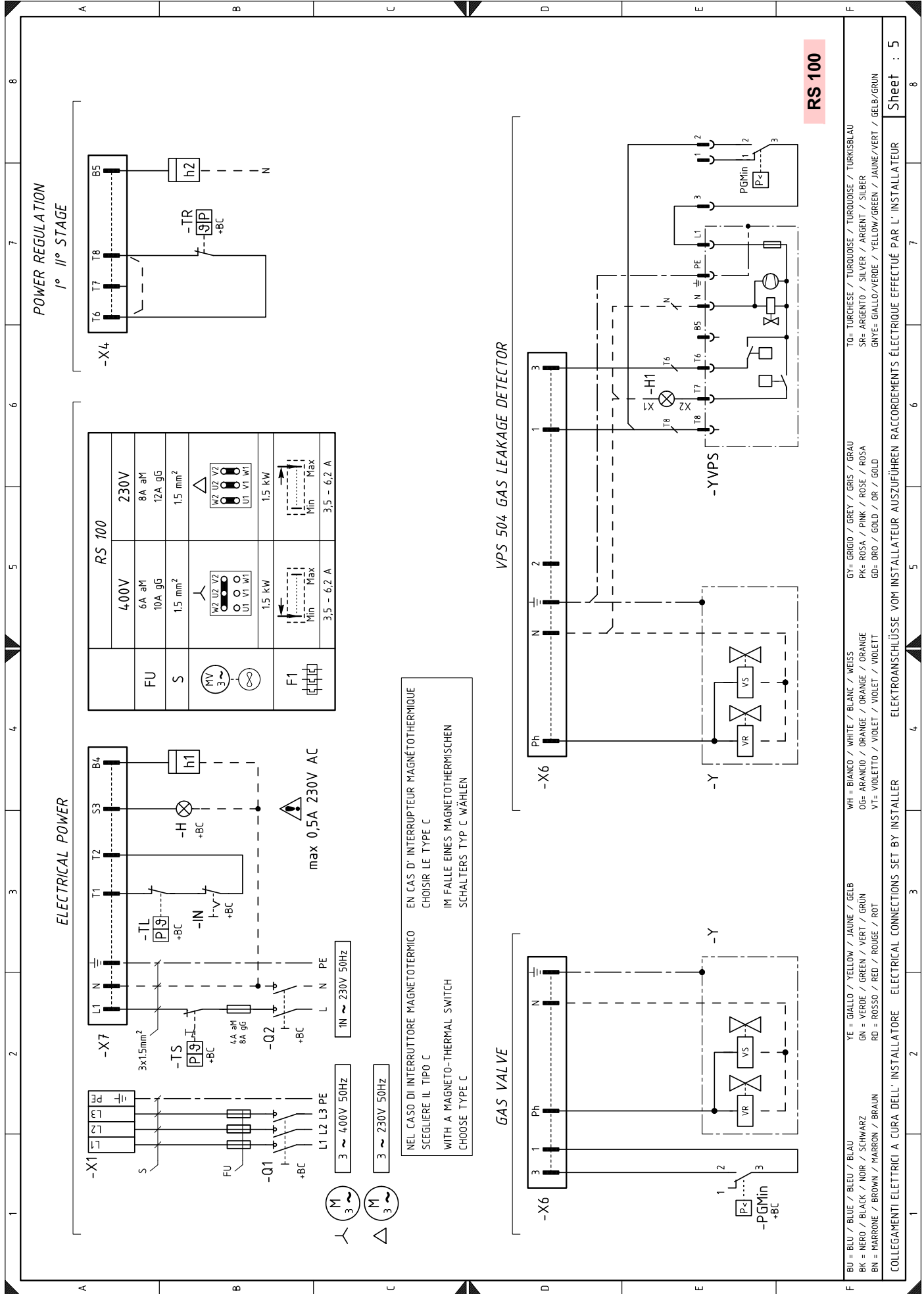

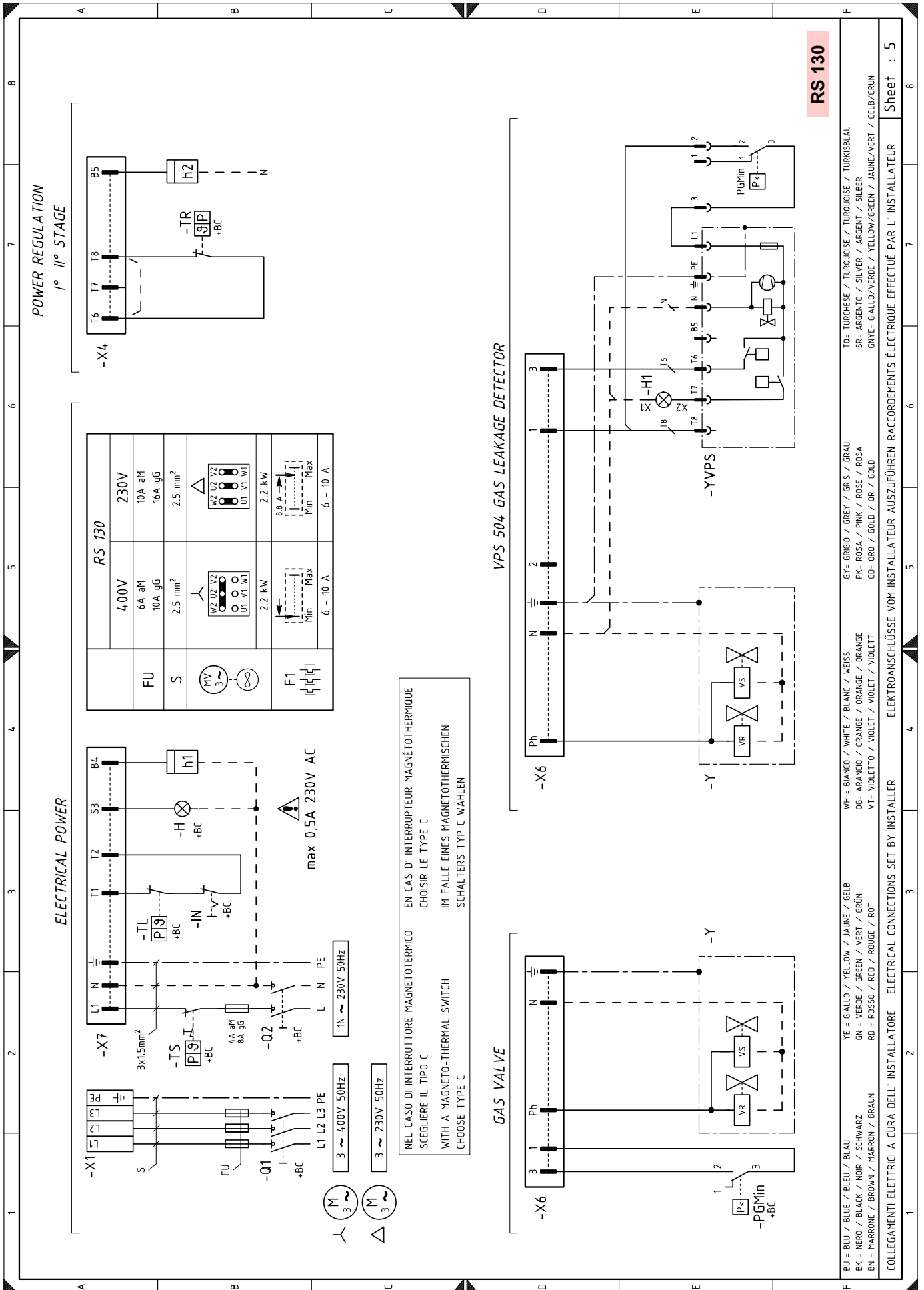

Wiring layout key

| | |
|-------|---|
| A1 | Control box |
| B | Filter to protect against radio disturbance |
| CN1 | Ionisation probe connector |
| FU | Fuse |
| F1 | Thermal relay |
| H | Lockout signal lamp |
| H1 | Valve leak detection device lockout signal lamp |
| h1 | 1st stage hour counter |
| h2 | 2nd stage hour counter |
| K1 | Relay |
| KM | Motor contactor |
| IN | Burner manual stop switch |
| ION | Ionisation probe |
| MV | Fan motor |
| PA | Air pressure switch |
| PGmin | Minimum gas pressure switch |
| Q1 | Three-phase line switch/disconnecting switch |
| Q2 | Single-phase line disconnecting switch |
| S1 | "On-Off" and "1st - 2nd stage" |
| SM | Servomotor |
| TA | Ignition transformer |
| TL | Limit pressure switch/thermostat |
| TR | Adjustment thermostat/pressure switch |
| TS | Safety pressure switch/thermostat |
| X1 | Burner terminal strip |
| X4 | 4 pin plug |
| X6 | 6 pin plug |
| X7 | 7 pin plug |
| Y | Gas valves |
| YVPS | Valve leak detection device |

RIELLO

RIELLO S.p.A.
I-37045 Legnago (VR)
Tel.: +39.0442.630111
[http:// www.riello.it](http://www.riello.it)
[http:// www.riello.com](http://www.riello.com)